

A Patient Satisfaction Theory and Its Robustness Across Gender in Emergency Departments: A Multigroup Structural Equation Modeling Investigation

Stephen J. Aragon, PhD, and Sabina B. Gesell, PhD

This investigation tested the patient-centered Primary Provider Theory of Patient Satisfaction across gender in national random samples of emergency patients. Using multigroup structural equation modeling, the results supported the model's robustness. Physician service, waiting time, and nursing satisfaction explained 48%, 41%, and 11 % of overall satisfaction plus 92% and 93% of female and male satisfaction, respectively. Unit increases in physician service satisfaction increased waiting time, nursing, and overall satisfaction by 0.991, 0.844, and 1.031 units, respectively. Unit increases in waiting time satisfaction increased nursing and overall satisfaction by 0.417 and 0.685 units, respectively. A unit increase in nursing satisfaction increased overall service satisfaction by 0.221 units. The investigation offers an alternative paradigm for measuring and achieving emergency department satisfaction, hierarchically related to patient expectations, where the primary provider has the greatest clinical utility to patients, followed by waiting for the primary provider, and then by nursing service.

Key words: Emergency department, model, patient satisfaction measurement, primary provider theory, quality.

Health services researchers have endeavored to identify the underlying structure of patient service satisfaction for some time. Nevertheless, the progression of new knowledge in this regard has been modest. Concurrently, The Institute of Medicine has published several compelling reports recommending a new level of partnership between clinicians and patients and that health care organizations and providers adopt a new level of "patient-centered" care to ensure that clinical

decisions respect patients desires (see *Crossing the Quality Chasm* [1] and *Envisioning a National Health Care Quality Report* [2], 2001, for review). However, despite these recommendations and recognition of both its clinical and service importance, no generally accepted theory of patient satisfaction has emerged in the published health care research.

Contributing to this state, various methodological problems have plagued the measurement of patient satisfaction. For example, methodological issues regarding the definition, measurement, reliability, validity, and factor structure of customer satisfaction have been cited (3). With specific regard to patient service satisfaction, the lack of generalizability, an inordinate reliance on nested samples (eg, representing a hospital or an organization), the inadequate consideration of measurement error, a methodological inertia, a knowledge plateau, and the absence of a unifying theory have all been pointed out (4). Plainly, these shortcomings can contribute to misunderstandings regarding patient service satisfaction.

Nevertheless and to their credit, hospitals across the country are increasingly implementing new programs to improve patient service satisfaction. Three fundamental realities appear to be driving this momentum. First, it is clear that patient satisfaction significantly affects a hospital's reputation in the community (5). Second, patient satisfaction has been accepted as an important measure of service quality (6-11). Third, physicians are paying increased attention to patient satisfaction because of its association with patient compliance (12), clinical outcomes (13), and, most recently, its association with a patient's propensity to instigate legal action against clinicians (14,15). Unquestionably, the frequency of patient complaints can be used by in-

Dr Aragon is Associate Dean and Professor, The School of Health Sciences, Winston-Salem State University, Winston-Salem, NC; and Dr Gesell is Senior Research Associate, Research and Development, Press Ganey Associates, Inc, South Bend, IN.

Corresponding author: Stephen J. Aragon, PhD, The School of Health Sciences, Winston-Salem State University, PO Box 19493, Winston-Salem, NC 27110 (e-mail: aragons@Wssu.edu).

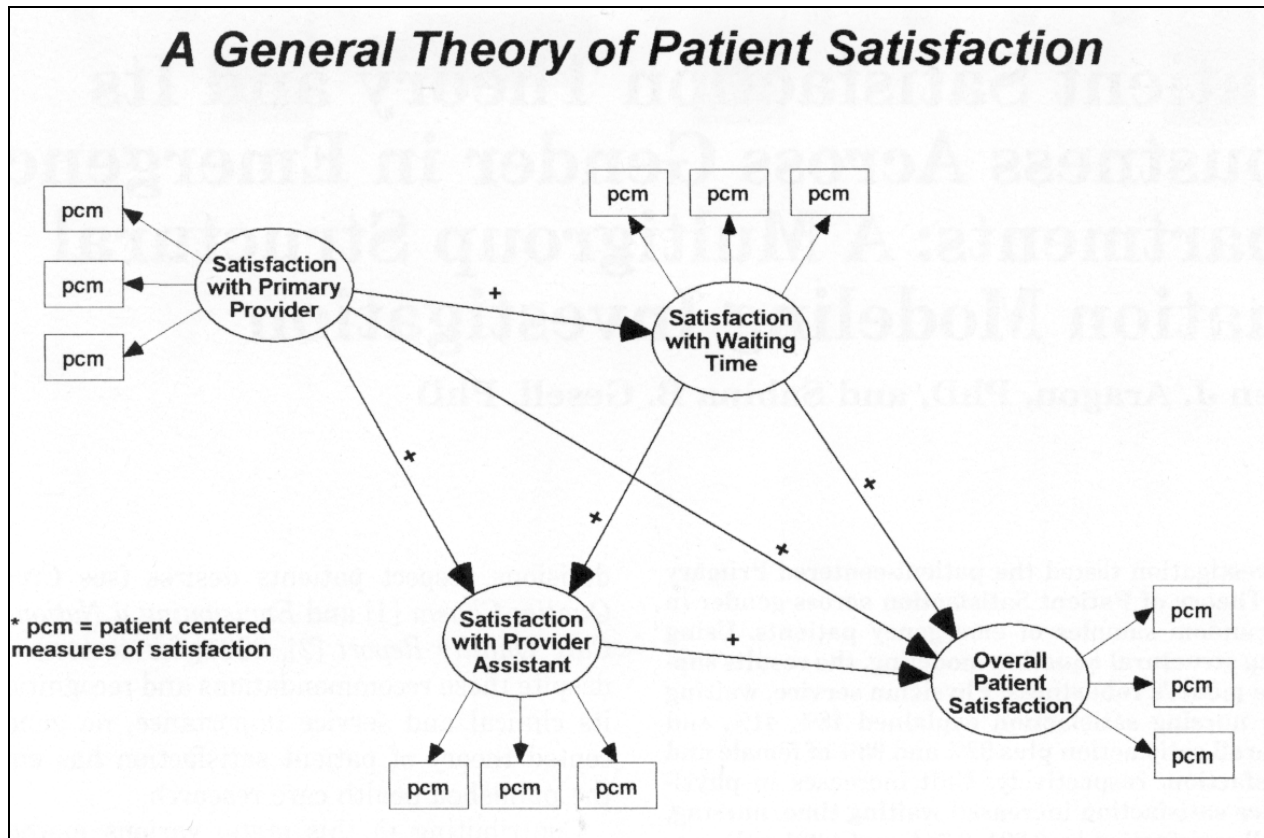

Figure 1. Primary Provider Theory of Patient Service Satisfaction.

insurance companies and credentialing entities to illuminate physicians at high risk for malpractice, after adjusting for clinical activity. In this light, it has been recommended that patient satisfaction measurement be used to forewarn physicians of their risk of being sued (16).

The broader marketing research provides several paradigms to explain customer satisfaction, including the value percept disparity theory, as well as the expectation-disconfirmation comparison level and equity-norms comparison models (see Yi [3] for review). Although perhaps applicable in some settings, these models are not readily mapped to patient satisfaction in a medical practice or hospital emergency department without some difficulty.

A new theory of patient service satisfaction, the Primary Provider Theory (4), suggests that the inception of satisfaction (or dissatisfaction) largely occurs at the nexus of patient expectations and the primary provider's power. Graphically represented in Figure 1 for an ambulatory setting, the theory holds that patient service satisfaction is principally the function of an un-

derlying or latent network of satisfaction constructs that usually includes satisfaction with the primary provider, waiting time, and the primary provider's assistants. This theory hierarchically relates its satisfaction constructs to patient expectations, conceding that the primary provider has the greatest clinical utility to patients, followed by time spent waiting for the primary provider, and then by the provider's assistants (4). It is noteworthy that the theory is operationalized by patient-centered measures exclusively, and only patients judge the quality of service. All other judgments are immaterial.

When the theory is mapped to a hospital emergency department, the primary provider becomes the emergency room physician. Satisfaction with waiting time equates to the patient's perception of waiting time for the physician, and satisfaction with nursing service is the corollary to satisfaction with the primary provider's assistants. In the emergency department, the Primary Provider Theory holds that overall service satisfaction (OS) is the function of patient satisfaction with physician service (SP), patient satisfaction with

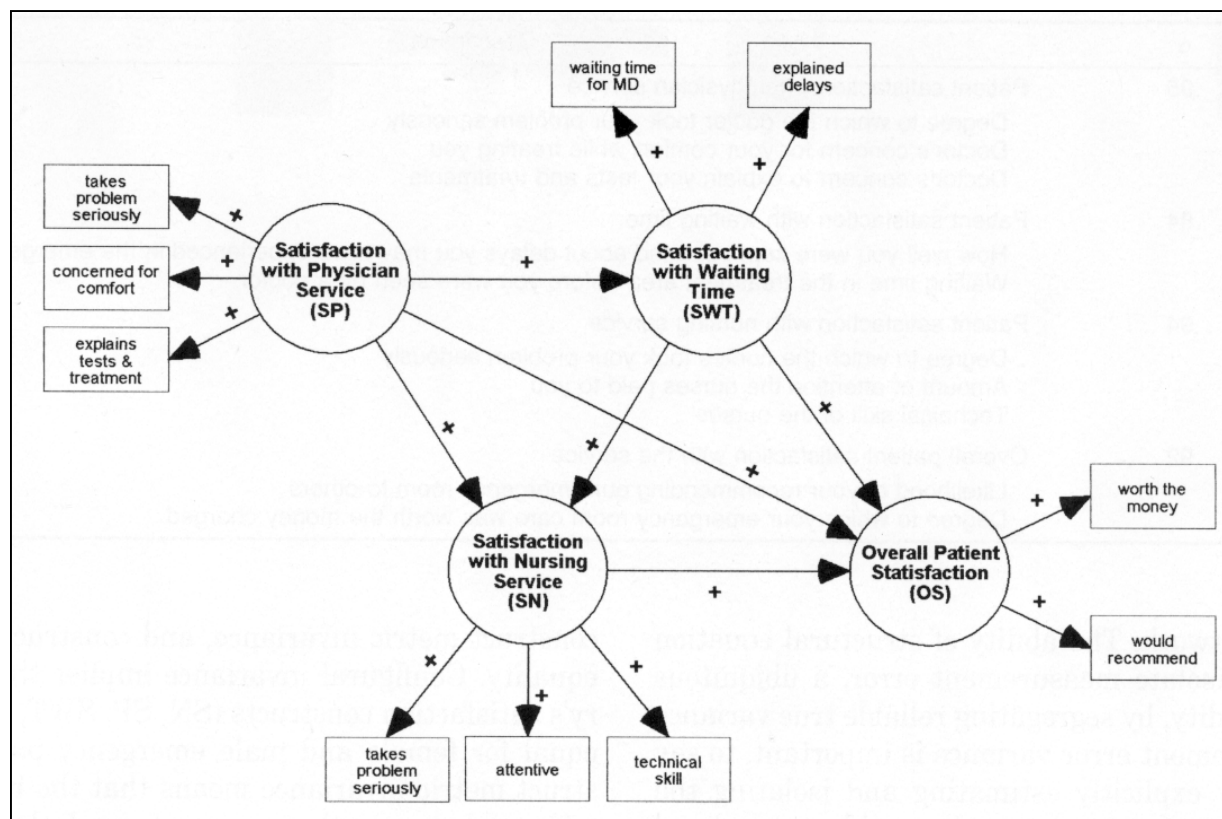

waiting time (SWT), and patient satisfaction with nursing service (SN), hierarchically related to the patient's expectation that the physician provides the greatest clinical value, followed by waiting for the physician, and then satisfaction with the nursing service (Figure 2). In this regard, the literature provides ample evidence that satisfaction with waiting time (17-28), nursing service (17, 21-23, 25-31), and physician service (17, 19, 21, 23, 25-31) influence overall emergency room service satisfaction.

Using national random samples of emergency department patients, the primary aim of this investigation was to test the robustness of the Primary Provider Theory across gender or, more specifically, whether the theory's structural relationships were invariant or equal in samples of male and female emergency department patients. Previous research has implied that patient's sex does not materially influence emergency department patient satisfaction (32-40). This suggests that a single underlying covariance structure may represent both male and female patients regarding emergency department service satisfaction. This proposition is testable and one of the considerations of this study. The Primary Provider Theory's key variables, SP,

SWT, SN, and OS, are latent factors or constructs, meaning they are not directly measured but rather indirectly assessed from observed variables. To illustrate, in this investigation SP is a construct that is simultaneously measured by 3 observed variables: (a) satisfaction with how seriously the physician views the patient's problem, (b) satisfaction with the physician's concern for the patient's comfort during treatment, and (c) satisfaction with the physician's explanation of the treatment. The common variance from these 3 observed variables, sans measurement error, gives mathematical form to and operationalizes the construct SP. SWT, SN, and OS are also multi-indicator latent variables that are operationalized the same way. Positively, rather than relying on 1 indicator alone to capture their dimensionality, constructs like these rely on extracting the reliable variance of multiple indicators for their form.

Structural equation modeling was specifically chosen for this investigation because of its capacity to handle complex models with mediating relationships, multiple groups, measurement error, and observed and latent variables, and to simultaneously estimate from sample observations the population values of all vari-

Table 1
Variables and Cronbach Alpha (α)

Measure	α	Description
SP	.95	Patient satisfaction with physician service
C3		Degree to which the doctor took your problem seriously
C4		Doctor's concern for your comfort while treating you
C5		Doctor's concern to explain your tests and treatments
SWT	.84	Patient satisfaction with waiting time
F1		How well you were kept informed about delays you may have experienced in the emergency room
C1		Waiting time in the treatment area before you were seen by a doctor
SN	.94	Patient satisfaction with nursing service
B2		Degree to which the nurses took your problem seriously
B3		Amount of attention the nurses paid to you
B6		Technical skill of the nurses
OS	.92	Overall patient satisfaction with the service
F4		Likelihood of your recommending our emergency room to others
F3		Degree to which your emergency room care was worth the money charged

ables in a network. The ability of structural equation modeling to isolate measurement error, a ubiquitous threat to validity, by segregating reliable true variance from measurement error variance is important, to say the least. By explicitly estimating and isolating the measurement error in observed variables, structural equation modeling reveals true variance and its related effects of variables in a model. Lastly, it facilitates testing whether the hypothesized model fits or is supported by the empirical data.

METHODS

Design

This investigation used a multigroup structural equation-modeling design with cross-sectional national random samples of male ($n = 500$) and female ($n = 500$) emergency department patients, as well as a post-hoc plausibility analysis, using 2000 bootstrap samples of $n = 500$ each to cross-validate parameter population estimates. AMOS 4.0 (Analysis of Moment Structures) was used for this study.

Model Specification and Measures

The Primary Provider Theory was specified with its measurement and structural coefficients constrained to equality to test its structural invariance across patient sex. Specifically, the direction and strength of the paths with plus signs (+) in Figure 2 were specified to be equal in the female and male samples. Structural invariance in this context means configural invariance,

construct metric invariance, and construct covariance equality. Configural invariance implies that the theory's satisfaction constructs (SN, SP, SWT, and OS) are equal for female and male emergency patients. Construct metric invariance means that the relationships (effects) between the constructs and their observed variables are equal for male and female emergency room patients. Construct covariance equality means that the structural relationships (effects) among the theory's latent constructs are equal for both female and male patients. The theory's measures, excluding error variance terms for convenience, are provided in Table 1. Four errors were correlated due to tautologies.

Model Estimation

Given the multivariate kurtotic nature of the data, asymptotic distribution-free estimation was used to estimate the model's parameters. Mardia's measure of multivariate kurtosis exceeded 100 ($P < .05$) for both male and female samples. In addition, the model's parameters were reestimated using 2000 bootstrap samples of $n = 500$ for cross-validation and to measure estimation bias.

Model Evaluation

Evaluation of the modeled theory's robustness was judged on the basis of (a) the appropriateness of the direction, strength, and significance of parameter estimates; (b) the convergence of the parameter estimates with the estimates, standard errors, and confidence intervals from the 2000 bootstrap samples; (c)

Table 2

Patient Characteristics (Male Patients, *n* = 500; Female Patients, *n* = 500)

Dimension	Male Patients, (%)	Female Patients, (%)
Age		
0-19 y	17	15
20-29 y	9	13
30-39 y	12	17
40-49 y	11	14
50-59 y	15	11
60-69 y	15	11
70-79 y	15	11
80-89 y	5	6
90+ y	1	2
Arrival time		
7 AM-3 PM	42	43
3 PM-11 PM	41	43
11 PM-7 AM	17	14

Table 3

Facility Characteristics (*n* = 459 Emergency Departments)

Region	
Northeast	28%
Midwest	29%
West	14%
South	29%
Location	
Large city (more than 1 million)	7%
Medium-sized city (250,000-1 million)	13%
Suburb of city	19%
Small city (50,000-250,000)	40%
Rural/town (less than 50,000)	21%
Trauma level	
I	15%
II	66%
III	20%
Volume (emergency department visits per year)	
Mean :	29,551
Minimum	1458
Maximum !	96,000

statistical tests and fit indices, including the chi-square test of fit (χ^2), the root mean squared error of approximation (RMSEA), and the standardized root mean residual (SRMR); (d) a comparison of the constrained model with its unconstrained counterpart using the chi-square difference test (χ^2_{diff}) and the comparative fit index change (CFI Δ); and (e) the model's ability to explain the variance (*R*²) of satisfaction in both female and male emergency department patient samples.

Instrument

The Press Ganey Emergency Room Survey, which scores patient responses on a 5-point scale, from very poor (1) to very good (5), was used. Previous research documented the instrument's internal consistency (*a* = .92) (20). Procedurally, the questionnaire was mailed with a postpaid return envelope to a random sample of nonadmitted emergency room patients, with a signed cover letter assuring confidentiality. Completed surveys were collected by the hospitals and then sent to Press Ganey for coding and analysis.

Sample

As a proxy of the nation's 1997 population of 5057 emergency rooms and 92,819,892 patient visits, 15,000 full-information emergency room cases were randomly selected from the 1997 Press Ganey Emergency Room Database of 584,208 patient visits to 459 emergency departments in 43 states, representing the Northeast (28%), Midwest (29%), West (14%), and South (29%).

Two samples, 1 of 500 female patients and the other of 500 male patients, were then randomly selected from the parent sample of 15,000 for analysis. Patient demographics and facility characteristics are reflected in Tables 2 and 3.

RESULTS

Evidence converged in support of the modeled theory and its robustness across the female and male emergency department samples. SP, SWT, and SN significantly influenced as, and furthermore, the direction, strength, and significance of all parameter estimates were consistent with the theory (*P* < .001) (Figure 3 and Table 4). The modeled theory accounted for 92.4% of the variance of female satisfaction and 93.5% of male satisfaction (*P* < .05). This result was additionally supported by the 2000 bootstrap parameter estimates and confidence intervals (Table 5). All population parameter estimates (direction, strength, and significance) converged favorably with their bootstrap counterparts, reflecting minimal parameter estimate bias, in further support of the model's robustness (Table 4).

The magnitude of congruence between the model and the data was noteworthy. Statistical tests and indices reflect that the modeled theory fits well and was also gender invariant, $\chi^2 = 64.55$, *df* = 48, *P* = .388; RMSEA = 0.006, *P* < .05 = 1.00, RMSEA CL_{90%} = 0.00-0.02; SRMR = 0.0216. Furthermore, the postu-

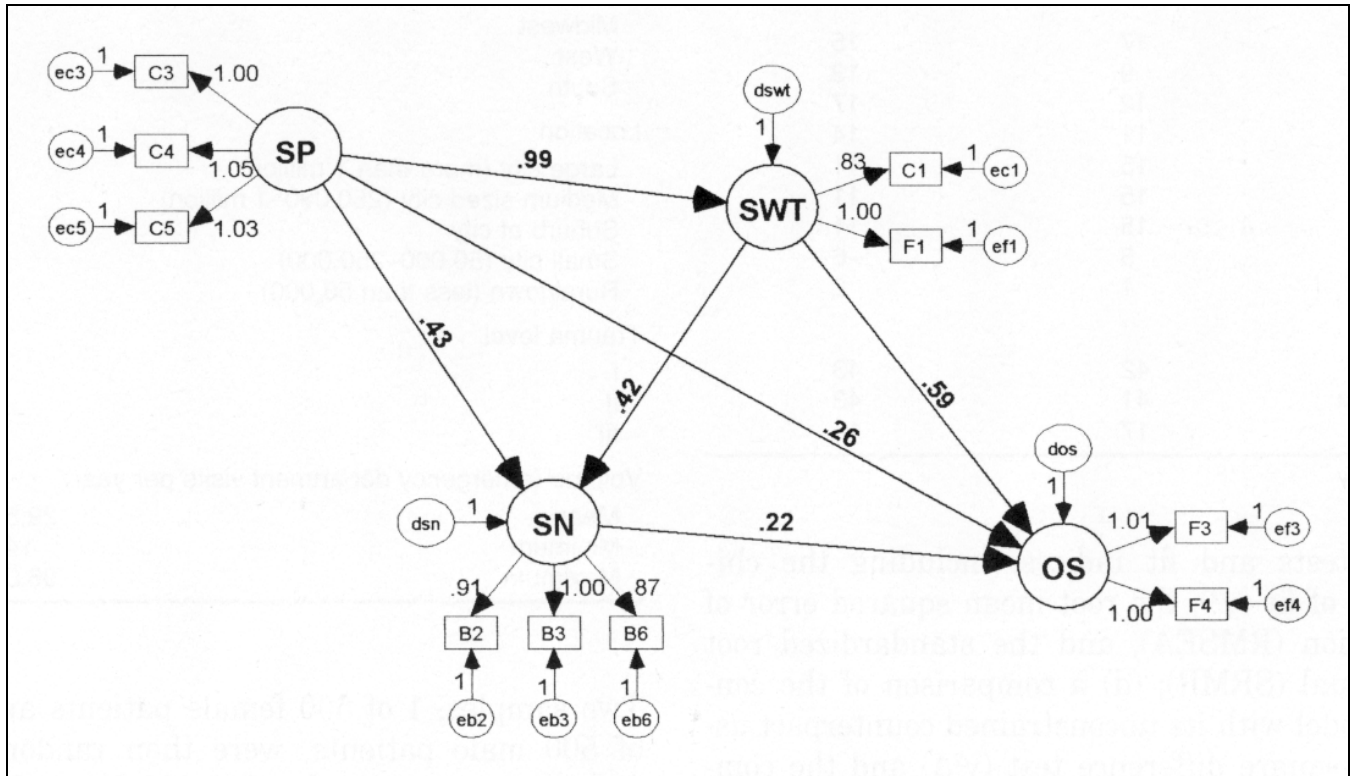

Figure 3. Understandardized estimates for female and male patients.

Table 4

Unstandardized Model ADF^a Estimates for Male and Female Emergency Department Patients (n = 500 Each) with Bootstrapped Means, Standard Errors, and 90% Confidence Intervals (CI) From 2000 Bootstrap Samples

Regression Weights	ADF Estimate (SE)	Bootstrap Mean (SE)	Parameter Estimate Bias	Bootstrap CI Lower 90%	Bootstrap CI Upper 90%	P*
SWT ← SP	0.991 (0.044)	1.017 (0.060)	.026	0.873	1.072	.012
SN ← SWT	0.417 (0.040)	0.399 (0.056)	-.019	0.339	0.518	.000
SN ← SP	0.431 (0.054)	0.461 (0.078)	.030	0.292	0.543	.008
OS ← SP	0.258 (0.055)	0.227 (0.071)	-.031	0.183	0.449	.000
OS ← SN	0.221 (0.069)	0.244 (0.086)	.022	0.036	0.335	.033
OS ← SWT	0.592 (0.054)	0.589 (0.065)	-.004	0.490	0.708	.001
B2 ← SN	0.913 (0.020)	0.914 (0.027)	.002	0.865	0.953	.002
B3 ← SN	1	1		1	1	-
B6 ← SN	0.870 (0.025)	0.880 (0.033)	0.010	0.801	0.913	.008
F4 ← OS	1	1		1	1	-
F3 ← OS	1.006 (0.016)	1.017 (0.020)	0.010	0.970	1.029	.022
F1 ← SWT	1	1		1	1	-
C1 ← SWT	0.834 (0.022)	0.840 (0.027)	0.007	0.785	0.874	.004
C3 ← SP	1	1		1	1	-
C4 ← SP	1.050 (0.020)	1.048 (0.024)	-.002	1.014	1.094	.000
C5 ← SP	1.026 (0.024)	1.027 (0.030)	.002	0.977	1.075	.001

^aADF = asymptotic distribution free.

* P < .001.

Table 5

Model Squared Multiple Correlations for Female and Male Emergency Department Patients (*n* = 500 Each) with Means, Standard Errors, and 90% Confidence Intervals (CI) from 2000 Bootstrap Samples

	Squared Multiple Correlations	Bootstrap Mean (SE)	Estimate Bias	Bootstrap CI Lower 90%	Bootstrap CI Upper 90%	<i>P</i>
Female patients	.924	0.929 (0.019)	.005	0.883	0.949	.008
Male patients	.935	0.931 (0.020)	-.004	0.904	0.971	.000

lated model fits the data better than its unconstrained counterpart, $\chi^2_d = 8.682$, $df = 12$, $P = .730$; $CFId (.995c -.988uc) = .007$.

Regarding the model's total effects, a unit increase in SP concomitantly increased satisfaction with SWT, SN, and as by 0.991, 0.844, and 1.031 units, respectively. Simultaneously, a unit increase in SWT was associated with concurrent increases of 0.417 and 0.685 in SN and as. In addition, a unit increase in SN increased as by 0.221 units. Taken together, SP and SWT had the greatest collective influence on as, accounting for approximately 48% and 41% of its variance, whereas SN accounted for 11% (Table 6).

The strength, consistency, significance, and invariance of the structural relationships (effects) among SP, SWT, SN, and as supported the validity and reliability of the model's inferences. This holds true for the structural relationships among SP, SWT, SN, as, and the observed variables that operationalize them as well. In addition, the size of the model's squared multiple correlations, which reflect the magnitude of variance attributable to the model's constructs and relationships, provided additional evidence supporting the validity and reliability of the model's inferences (Figures 4 and 5). Means and covariances for male and female samples are reported in Tables 7 through 10.

DISCUSSION

Unlike previous emergency department satisfaction research, this study was based on the Primary Provider Theory of Patient Satisfaction. Operationalized by patient-centered measures exclusively, where only patients judge quality and all other judgments are immaterial, the Primary Provider Theory was grounded in over 20 years of experience receiving patient complaints, investigating them, and triangulating the comments of physicians, nurses, and others to resolve them.

Maintaining that the inception of satisfaction or dissatisfaction occurs at the nexus of provider power and patient expectations, the theory holds that the primary provider has the greatest clinical utility to patients. In the emergency department, the theory posits that patient service satisfaction is principally the function of an underlying or latent network of satisfaction constructs, including patient satisfaction with the primary provider, waiting time, and the primary provider's assistants, hierarchically related to the patient's expectations.

Whereas most previous empirical emergency room satisfaction research has been based on nested samples (eg, patients from one or a few emergency depart-

Table 6

Total Effects of Patient Satisfaction with Physician Service, Waiting Time, and Nursing Service on Overall Service Satisfaction for Female and Male Emergency Department Patients (*n* = 500 Each)

Samples	Physician Service Satisfaction	Waiting Time Satisfaction	Nursing Service Satisfaction	Total
Standardized				
Females	0.831	0.724	0.184	1.739
Males	0.841	0.725	0.187	1.753
Total	1.672	1.449	0.371	3.492
% Total	48	41	11	100
Unstandardized				
Females	1.031	0.685	0.221	1.937
Males	1.031	0.685	0.221	1.937
Total	2.062	1.37	0.442	3.874
% Total	53	35	12	100

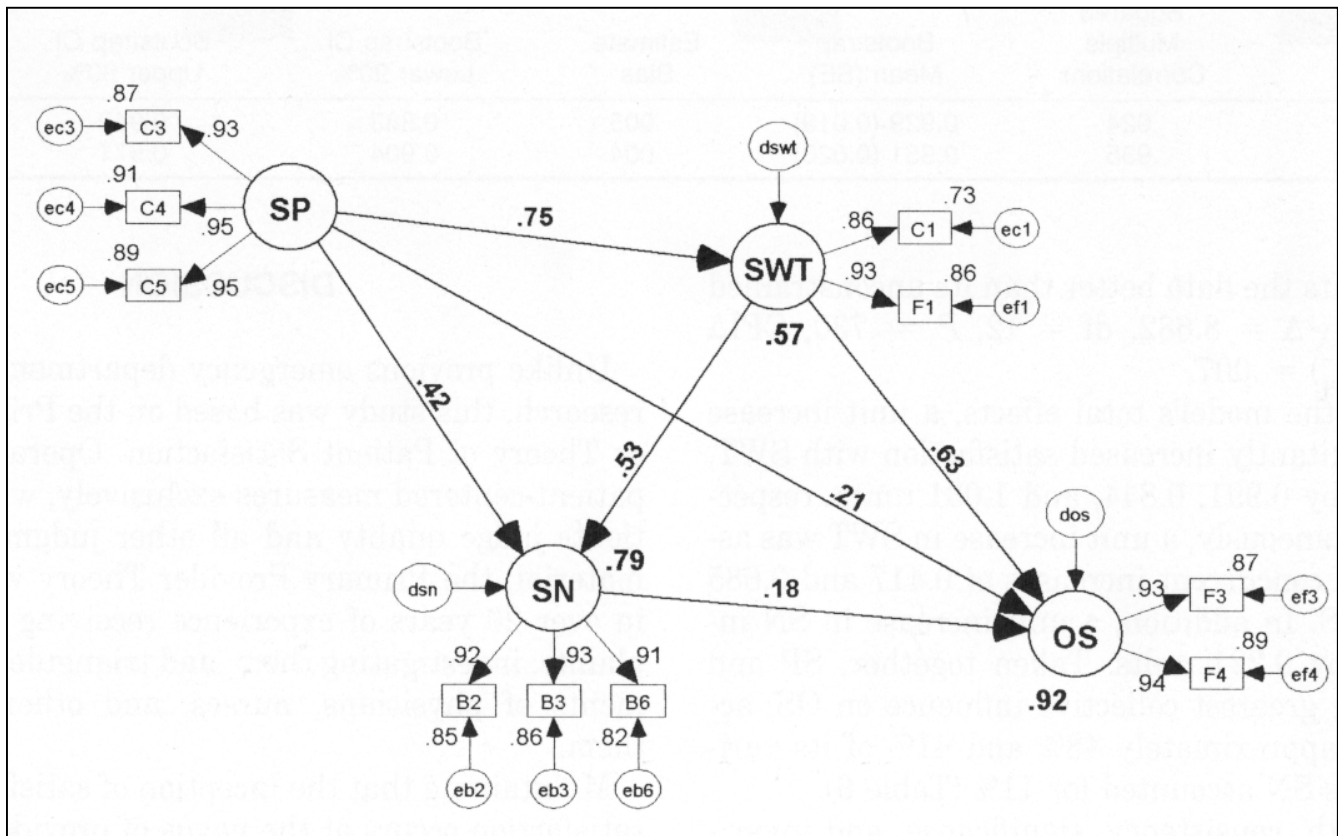

Figure 4. Standardized estimates for female patients.

ments or from one company, region, or class of hospitals), this investigation was based on random samples, of both patients and emergency departments from the national population. The investigation used multivariate structural equation modeling to explicitly estimate and isolate measurement error and to illuminate the disattenuated common or true variance (effects) among variables. Through the use of simultaneous multigroup analysis, this investigation also tested the invariance of the modeled theory across female and male emergency room patients. Then, the results were crossvalidated with 2000 bootstrap sample estimates. Unlike previous research, which implied that emergency room satisfaction conformed to an elementary regression model paradigm, devoid of mediating relationships, this study used a more comprehensive paradigm, which took into account the clinical utility of the primary provider, related patient expectations, and intervening effects. Aside from these differences, this investigation reaffirmed previous research, which found that patient satisfaction with physician service, waiting time, and nursing service were key factors in the measurement of overall service satisfaction.

Sustaining the Primary Provider Theory's robust-

ness across gender, this investigation provided evidence that emergency department satisfaction was principally the function of an underlying or latent network of patient-centered satisfaction constructs. Hierarchically related to patient expectations, these constructs included patient satisfaction with physician service, waiting time, nursing service, and overall service. Concomitantly, a unit increase in satisfaction with physician service increased satisfaction with waiting time, nursing service, and overall service. Simultaneously, a unit increase in satisfaction with waiting time was associated with increases in both satisfaction with nursing service and overall service. Lastly, a unit increase in satisfaction with nursing service increased overall service satisfaction as well. Patients' satisfaction with physician service and waiting time had the greatest collective influence on overall service satisfaction, accounting for the preponderance of its variance.

Furthermore, the results of this investigation revealed that the modeled Primary Provider Theory's structural relationships were invariant across both samples of male and female emergency department patients. This evidence of gender invariance is consistent

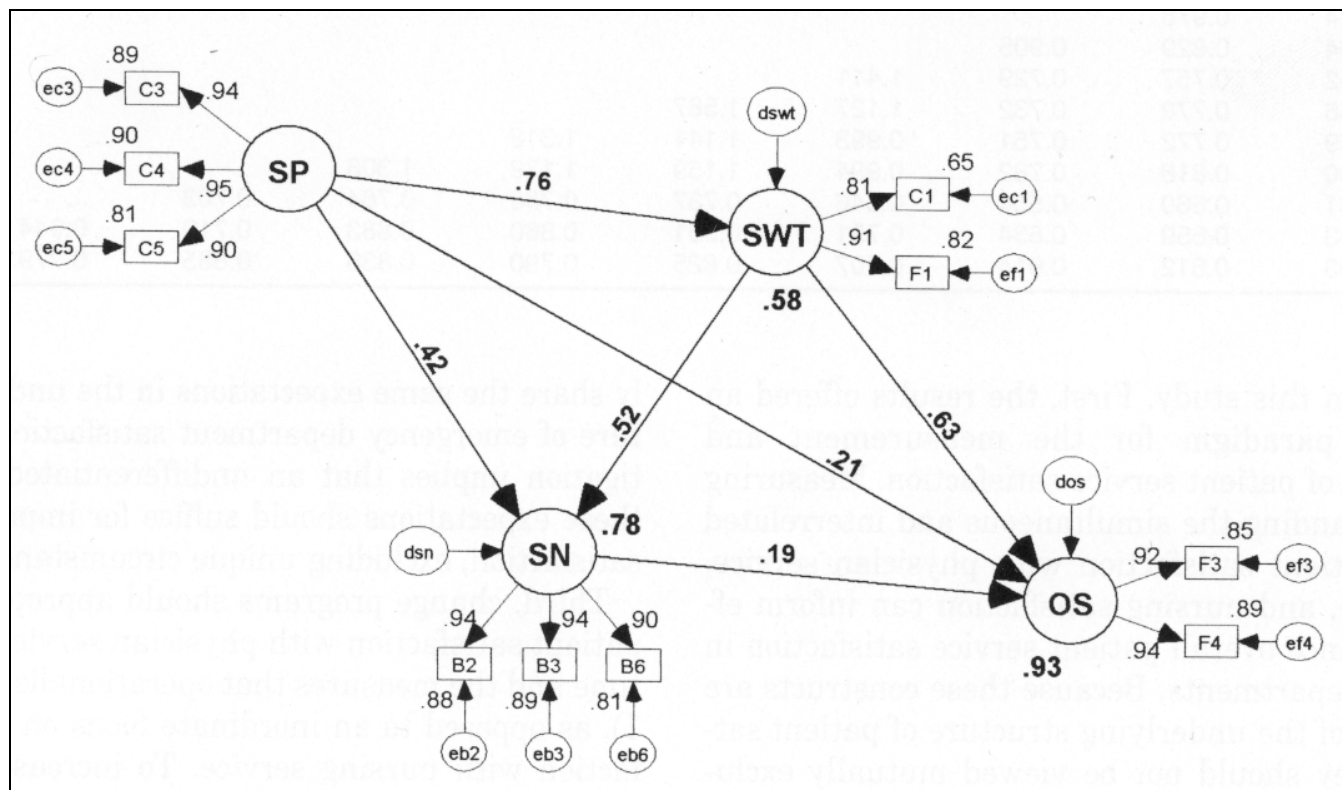

Figure 5. Standardized estimates for male patients.

with previous research and suggests that one underlying covariance matrix exists for male and female emergency department patients. In this regard, the study's results revealed that the Primary Provider Theory's constructs were equal for male and female emergency patients, and the effects of these constructs on their observed measures were equal regardless of the patient's sex. In addition, the relationships among patient satisfaction with physician service, waiting time, nursing service, and overall satisfaction were equal despite gender. More specifically, satisfaction

with physician service, waiting time, and nursing service had like effects on each other and on overall satisfaction for both men and women. Consistent with previous research, these results demonstrated that patient sex does not materially influence emergency department patient satisfaction.

Relevance to Delivery

Three general domains of knowledge regarding the implementation of patient satisfaction programs

Table 7

Means for Male Patients

Variable	Description	Mean
C5	Physician's effort to explain tests and treatments to the patient	4.34
C4	Physician's concern for patient's comfort	4.33
C3	Physician's serious regard for the patient's problem	4.40
C1	Waiting time in the treatment area before the patient is seen by the physician	3.89
F1	How well the patient was kept informed about waiting time delays	3.98
F3	Degree to which the care was worth the money	4.06
F4	Likelihood that the patient would recommend the emergency department to others	4.21
B6	Nurses' technical skill	4.45
B3	Nurses' attentiveness	4.30
B2	Nurses' serious regard for the patient's problem	4.46

Table 8
Covariances for Male Patients

	C5	C4	C3	C1	F1	F3	F4	B6	B3	B2
C5	1.047									
C4	0.874	0.976								
C3	0.804	0.829	0.905							
C1	0.752	0.757	0.729	1.411						
F1	0.766	0.778	0.732	1.127	1.587					
F3	0.779	0.772	0.751	0.993	1.141	1.318				
F4	0.800	0.818	0.782	0.994	1.159	1.139	1.308			
B6	0.541	0.560	0.554	0.646	0.737	0.738	0.764	0.763		
B3	0.643	0.659	0.634	0.791	0.901	0.860	0.883	0.719	0.944	
B2	0.593	0.612	0.614	0.707	0.825	0.790	0.836	0.685	0.779	0.840

emerged from this study. First, the results offered an alternative paradigm for the measurement and achievement of patient service satisfaction. Measuring and understanding the simultaneous and interrelated effects of patient satisfaction with physician service, waiting time, and nursing satisfaction can inform efforts to enhance overall patient service satisfaction in emergency departments. Because these constructs are components of the underlying structure of patient satisfaction, they should not be viewed mutually exclusively in the evaluation of service acceptability. Each has concomitant directional influences on service satisfaction, and together they account for most of its variance. Accordingly, the Primary Provider Theory can be used to guide the measurement of patient satisfaction, identify gaps, and implement patient satisfaction action plans. Along with quality improvement and outcome measurement, the results have some implications for emergency department physician staffing, contracting, practice, and education.

Second, the results of this investigation indicate that the return for implementing separate emergency department patient satisfaction improvement programs for men and women may not justify the investment. Male and female emergency department patients large-

ly share the same expectations in the underlying structure of emergency department satisfaction. This investigation implies that an undifferentiated approach to these expectations should suffice for improving service satisfaction, excluding unique circumstances.

Third, change programs should appropriately weigh patient satisfaction with physician service and waiting time and the measures that operationalize them (Table 1), as opposed to an inordinate focus on patient satisfaction with nursing service. To increase overall satisfaction, emergency department physicians might, for example, improve behavior and increase interactions that convey to the patient a serious regard for the patient and their health problem. This could involve increasing attention to verbal expressions and body language that cue interest and active listening. Conversely, physicians should avoid behaviors that might imply anything less than a serious regard for the patient's condition, like inappropriate joking, insufficient eye contact, lack of sincerity or communication with the patient, talking over the patient's head, appearing not to give undivided attention to the patient, or any other potentially distancing behavior. Physicians who convey that they take the patient's health problem seriously, are concerned for their comfort, and are interested in

Table 9
Means for Female Patients

Variable	Description	Mean
C5	Physician's effort to explain tests and treatments to the patient	4.26
C4	Physician's concern for patient's comfort	4.25
C3	Physician's serious regard for the patient's problem	4.30
C1	Waiting time in the treatment area before the patient is seen by the physician	3.85
F1	How well the patient was kept informed about waiting time delays	3.83
F3	Degree to which the care was worth the money	3.90
F4	Likelihood that the patient would recommend the emergency department to others	4.10
B6	Nurses' technical skill	4.38
B3	Nurses' attentiveness and informativeness	4.23
B2	Nurses' serious regard for the patient's problem	4.37

Table 10
Covariances for Female Patients

	C5	C4	C3	C1	F1	F3	F4	B6	B3	B2
C5	1.034									
C4	0.913	1.096								
C3	0.878	0.953	1.056							
C1	0.746	0.788	0.724	1.476						
F1	0.916	0.892	0.861	1.257	1.820					
F3	0.967	0.970	0.939	1.103	1.383	1.604				
F4	0.933	0.930	0.923	1.097	1.331	1.362	1.520			
B6	0.639	0.643	0.614	0.732	0.855	0.828	0.830	0.863		
B3	0.768	0.797	0.773	0.879	1.039	1.004	1.022	0.820	1.159	
B2	0.683	0.710	0.701	0.773	0.877	0.863	0.881	0.718	0.870	0.896

explaining the tests and treatments will garner more satisfaction than those who do not. Technical competence is a fundamental expectation of patients. With the greatest magnitude of a priori utility, patient satisfaction with physician service is the most powerful satisfaction accelerator in the underlying network of emergency department satisfaction. Although unit increases in patient satisfaction with physician service, waiting time, and nursing service evoke increases in overall emergency room satisfaction, the findings of this investigation indicate that the effect of patient satisfaction with physician service is sufficiently powerful to overcome some dissatisfaction with waiting time or nursing service. In the interaction between the physician and the patient, the patient requests help from the physician. The requested help may include not only a diagnosis, treatment, drugs, relief of pain, information, a cure, or other similar clinical help but also sincerity, kindness, compassion, respect, trust, honesty, encouragement, or other similar effective help. There is tremendous stress these days on evidence-based clinical outcomes. These alone are never enough. Successful medical providers endeavor to satisfy their patient's reasonable expectations as well as to achieve optimum clinical outcomes.

Improving the next most powerful lever in the satisfaction hierarchy, patient satisfaction with waiting time, will also characterize successful patient satisfaction programs. Strategies for improving this fundamental element of patient satisfaction are limited only by the creativity of the change agent. Everything from frequently informing patients about delays in their care to changing patients' perceptions of waiting lines can positively influence patient satisfaction with waiting time. As increasing the number of checkout counters in a department store will reduce the length of customer lines, increasing the number of physicians serving in an emergency department will often reduce the length of patient lines, space permitting.

Limitations

One instrument, the Press Ganey Emergency Room Survey, was the sole source of all variables and cases for this investigation. Although the instrument is the most widely used instrument to measure satisfaction nationally, other surveys such as those used by Bursch et al (15), Thompson et al (23), and Professional Research Corporation might also be used for this type of study. The Press Ganey instrument was used for this study because its database is the largest and best known to the authors. Furthermore, the hospitals in the 1997 Press Ganey Emergency Room database resemble the national population of hospitals by region, trauma level, and volume. The database does not include patient satisfaction data from each and every hospital emergency department and patient in the nation and, therefore, could contain some degree of selection bias. No database is known to the authors that includes every hospital emergency department and patient in the nation. Patients who were admitted are not included in this study. Expert opinion, in this regard, indicates that admitted patients do not represent substantive dissatisfaction in emergency departments as a group.

The names of the latent variables in this investigation are based on the items that operationalize them, as determined by researcher judgment. Opinions can always differ regarding latent variable names. Covariance matrix fit indices are subject to various effects (sample size, distributional assumption violation, model misspecification, estimation method, and other effects); consequently, they should not be regarded as perfect measures of model propriety.

Lastly, although the investigation provided substantive evidence, it alone cannot ultimately confirm the Primary Provider Theory. The ultimate validity and reliability of the theory's inferences must be demonstrated by the weight and convergence of a future body of research.

Recommendations for Future Research

It is recommended that the Primary Provider Theory be tested under a variety of conditions, data sets, and instruments to further examine the validity and reliability of its inferences. It can be partitioned into sub-theories and each subtheory be tested individually. For example, the theory's fundamental measurement structure can be tested independently, and the influence of patient satisfaction with physician service and waiting time on nursing service should be investigated independently. Future research should also investigate the theory's robustness over time and emergency department size or volume. Examination of the theory's applicability in other settings would be useful. For example, the theory's fundamental structural assumptions might be tested in urgent care and physician office settings.

SUMMARY

Using multigroup structural equation modeling, this investigation tested the Primary Provider Theory, a patient-centered approach to the measurement of service satisfaction, across patient sex in national random samples of emergency patients. The Primary Provider Theory holds that the inception of patient satisfaction (or dissatisfaction) largely occurs at the nexus of patient expectations and primary provider power and that overall satisfaction is principally the function of an underlying or latent network of satisfaction constructs, including satisfaction with the primary provider, waiting time, and the primary provider's assistants. This theory's satisfaction constructs are hierarchically related to patient expectations, recognizing that the primary provider has the greatest clinical utility to patients. The theory is exclusively operationalized by patient-centered measures, and only patients judge the quality of service. All other judgments are immaterial. Mapped to an emergency department, the Primary Provider Theory holds that overall service satisfaction (aS) is the function of patient satisfaction with physician service (SP), waiting time (SWT), and nursing service (SN), hierarchically specified according to patients' related expectations.

Sustaining the Primary Provider Theory's robustness across gender, this investigation provided evidence that emergency department satisfaction was principally the function of the Theory's underlying network of satisfaction constructs. Unit increases in physician service satisfaction increased waiting time, nursing, and overall satisfaction by 0.991, 0.844, and

1.031 units, respectively. Unit increases in waiting time satisfaction increased nursing and overall satisfaction by 0.417 and 0.685 units, respectively. Lastly, a unit increase in nursing service satisfaction increased overall satisfaction by 0.221 units. Patients' satisfaction with physician service and waiting time had the greatest collective influence on overall service satisfaction, explaining the preponderance of its variance. Physician service, waiting time, and nursing satisfaction explained 48%, 41%, and 11% of overall service satisfaction and 92% and 93% of female and male satisfaction, respectively. The investigation offers an alternative paradigm for measuring and achieving emergency department satisfaction.

ACKNOWLEDGMENTS

This research was partially supported by a National Research Service Award postdoctoral fellowship from the Agency for Health Care Research and Quality sponsored by the Cecil G. Sheps Center for Health Services Research, University of North Carolina at Chapel Hill, grant T32 HS00032.

References

1. Institute of Medicine. Committee on the National Quality Report on Health Care Delivery. Board of Health Care Services. *Envisioning the National Health Care Quality Report*. Hurtado MP, Swift EK, Corrigan, JM, eds. Washington, DC: National Academy Press; 2000.
2. Institute of Medicine. Committee on Health Care in America. *Crossing the Quality Chasm: A New Health System for the 21st Century*. Washington DC: National Academy Press; 2001.
3. Yi Y. A critical review of consumer satisfaction. In: Zeithaml V, ed. *Review of Marketing 1990*. Chicago: American Marketing Association; 1991:68-123.
4. Aragon SJ. *The Latent Structure of Emergency Room Satisfaction: A Structural Equation Modeling Investigation* [dissertation]. Greensboro, NC: University of Chapel Hill; 2000.
5. The Advisory Board Company. Heightened service scrutiny. In: *Emergency Care Reform: Executive Briefing for Clinical Leaders*. Clockwork ED Series. Washington, DC: The Advisory Board Company; 1998:23-46.
6. Donabedian A. The quality of care: how can it be assessed? *JAMA*. 1988;260:1743-1748.
7. Drain M. Quality improvement in primary care and the importance of patient satisfaction. *J Ambul Care Manag*. 2001;24:30-46.
8. Pascoe GC. Patient satisfaction in primary health care: a literature review and analysis. *Eool Program Plann*. 1983;6:185-210.
9. Press I. Patient satisfaction. *Hosp Health Netw*. 1994;68:60. 10. Steiber SR, Krowinski WJ. *Measuring and Managing Patient Satisfaction*. Chicago: American Hospital Publishing; 1990.
10. Ware JE, Davies AR. Behavioral consequences of consumer dissatisfaction with medical care. *Eool Program Plann*. 1983;6:291-297.
11. Ware JE, Hays RD. Methods for measuring patient satisfaction with specific medical encounters. *Med Care*. 1988;26:3-3-402.
12. Kenagy JW, Berwick DM, Shore MF. Service quality in health care. *JAMA*. 1999;281:661-665.

13. Pichert JW, Miller CS, Hollo AH, et al. What health professionals can do to identify and resolve patient dissatisfaction? *Jt Comm J Qual Improv.* 1998;24:303-312.
14. Spiegel AD, Kavalier F. Better patient communications means lower liability exposure. *Manag Care.* August 1997;119-124.
15. Hickson GB, Federspiel CF, Pichert JW, et al. Patient complaints and malpractice risk. *JAMA.* 2002;287:2951-2957.
16. Bursch B, Beezy J, Shaw R. Emergency department satisfaction: what matters most? *Ann Emerg Med.* 1993;22:586-591.
17. Hansagi H, Carlsson B, Brismar B. The urgency of care need and patient satisfaction at a hospital emergency department. *Health Care Manag Rev* 1992;17:71-75.
18. Maitra A, Chikhani C. Patient satisfaction in an urban accident and emergency department. *Br J Clin Pract.* 1992;46:182-184.
19. McMillan JR, Younger MS, DeWine LC. Satisfaction with hospital emergency department as a function of patient triage. *Health Care Manag Rev* 1986;11:21-27.
20. Mowen JC, Licata JW, McPhail J. Waiting in the emergency room: how to improve patient satisfaction. *J Health Care Mark.* 1993;13:26-33.
21. Rhee KJ, Bird J. Perceptions and satisfaction with emergency department care. *J Emerg Med.* 1996;14:679-683.
22. Rhee KJ, Allen RA, Bird J. Telephone vs mail response to an emergency department patient satisfaction survey. *Acad Emerg Med.* 1998;5:1121-1123.
23. Thompson DA, Yarnold PR. Relating patient satisfaction to waiting time perceptions and expectations: the disconfirmation paradigm. *Acad Emerg Med.* 1995;2:1057-1062.
24. Thompson DA, Yarnold PR, Williams DR, et al. Effects of actual waiting time, perceived waiting time, information delivery, and expressive quality on patient satisfaction in the emergency department. *Ann Emerg Med.* 1996;28:657-665.
25. Carey RG, Seibert JH. A patient survey system to measure quality improvement: questionnaire reliability and validity. *Med Care.* 1993;31:834-845.
26. Hall MF, Press I. Keys to patient satisfaction in the emergency department: results of a multiple facility study. *Hosp Health Serv Adm.* 1996;41:515-532.
27. Yarnold PR, Michelson EA, Thompson DA, et al. Predicting patient satisfaction: a study of two emergency departments. *J Behav Med.* 1998;21:545-563.
28. Bjorvell H, Stieg J. Patients' perceptions of the health care received in an emergency department. *Ann Emerg Med.* 1991;20:734-738.
29. Burroughs TE, Davies AR, Cira JC, et al. Understanding patient willingness to recommend and return: a strategy for prioritizing improvement opportunities. *Jt Comm J Qual Improv.* 1999;25:271-287.
30. Mack JL, File KM, Horwitz JE, et al. The effect of urgency on patient satisfaction and future emergency department choice. *Health Care Manag Rev* 1995;20:7-15.
31. Boudreaux ED, Ary RD, Mandry CV, et al. Determinants of patient satisfaction in a large municipal ED: the role of demographic variables, visit characteristics and patient perceptions. *Am J Emerg Med.* 2000;18:394-400.
32. Campanella HC, Campanella PM, Grayson KG. Factors affecting department of defense patient satisfaction in a military emergency department. *Mil Med.* 2000;165:396-402.
33. Hall MF, Press I. Keys to patient satisfaction in the emergency department: results of a multiple facility study. *Hosp Health Serv Adm.* 1996;41:515-532.
34. Nerny MP, Chin MR, Jin L, et al. Factors associated with older patients' satisfaction with care in an inner-city emergency department. *Ann Emerg Med.* 2001;38:140-145. Raper J, Davis BA, Scott L. Patient satisfaction with emergency department triage nursing care: a multicenter study. *J Nurs Care Qual.* 1999;13:11-24.
35. Sun BC, Adams J, Orav EJ, et al. Determinants of patient satisfaction and willingness to return with emergency care. *Ann Emerg Med.* 2000;35:426-434.
36. Thomson DA, Yarnold PR, Williams DR, et al. Effects of actual waiting time, perceived waiting time, information delivery, and expressive quality on patient satisfaction in the emergency department. *Ann Emerg Med.* 1996;28:657-665.
37. Hall JA, Dorman MC. Patient sociodemographic characteristics as predictors of satisfaction with medical care: a meta-analysis. *Soc Sci Med.* 1990;30:811-818.
38. The American Hospital Association. *Hospital Statistics.* Chicago: Healthcare InfoSource; 1999.