

# AutoSketch<sup>®</sup> 10 Getting Started

**Autodesk<sup>®</sup>**

October 2008

© 2008 Autodesk, Inc. All rights reserved. Except as otherwise permitted by Autodesk, Inc., this publication, or parts thereof, may not be reproduced in any form, by any method, for any purpose.

Certain materials included in this publication are reprinted with the permission of the copyright holder.

## Trademarks

The following are registered trademarks or trademarks of Autodesk, Inc., in the USA and other countries: 3DEC (design/logo), 3December, 3December.com, 3ds Max, ADI, Alias, Alias (swirl design/logo), AliasStudio, AliasWavefront (design/logo), ATC, AUGI, AutoCAD, AutoCAD Learning Assistance, AutoCAD LT, AutoCAD Simulator, AutoCAD SQL Extension, AutoCAD SQL Interface, Autodesk, Autodesk Envision, Autodesk Insight, Autodesk Intent, Autodesk Inventor, Autodesk Map, Autodesk MapGuide, Autodesk Streamline, AutoLISP, AutoSnap, AutoSketch, AutoTrack, Backdraft, Built with ObjectARX (logo), Burn, Buzzsaw, CAiCE, Can You Imagine, Character Studio, Cinestream, Civil 3D, Cleaner, Cleaner Central, ClearScale, Colour Warper, Combustion, Communication Specification, Constructware, Content Explorer, Create>what's>Next> (design/logo), Dancing Baby (image), DesignCenter, Design Doctor, Designer's Toolkit, DesignKids, DesignProf, DesignServer, DesignStudio, DesignStudio (design/logo), Design Web Format, DWF, DWG, DWG (logo), DWG Extreme, DWG TrueConvert, DWG TrueView, DXF, Ecotect, Exposure, Extending the Design Team, FBX, Filmbox, FMDesktop, Freewheel, GDX Driver, Gmax, Green Building Studio, Heads-up Design, Heidi, HumanIK, IDEA Server, i-drop, ImageModeler, iMOUT, Incinerator, Inventor, Inventor LT, Kaydara, Kaydara (design/logo), Kynapse, Kynogon, LandXplorer, LocationLogic, Lustre, Matchmover, Maya, Mechanical Desktop, MotionBuilder, Movimento, Mudbox, NavisWorks, ObjectARX, ObjectDBX, Open Reality, Opticore, Opticore Opus, PolarSnap, PortfolioWall, Powered with Autodesk Technology, Productstream, ProjectPoint, ProMaterials, RasterDWG, Reactor, RealDWG, Real-time Roto, REALVIZ, Recognize, Render Queue, Retimer, Reveal, Revit, Showcase, ShowMotion, SketchBook, SteeringWheels, Stitcher, StudioTools, Topobase, Toxik, TrustedDWG, ViewCube, Visual, Visual Construction, Visual Drainage, Visual Landscape, Visual Survey, Visual Toolbox, Visual LISP, Voice Reality, Volo, Vtour, Wiretap, and WiretapCentral.

The following are registered trademarks or trademarks of Autodesk Canada Co. in the USA and/or Canada and other countries: Backburner, Discreet, Fire, Flame, Flint, Frost, Inferno, Multi-Master Editing, River, Smoke, Sparks, Stone, and Wire.

The following are registered trademarks or trademarks of Moldflow Corp. in the USA and/or other countries: Moldflow MPA, MPA (design/logo), Moldflow Plastics Advisers, MPI, MPI (design/logo), Moldflow Plastics Insight, MPX, MPX (design/logo), Moldflow Plastics Xpert.

All other brand names, product names or trademarks belong to their respective holders.

## Disclaimer

THIS PUBLICATION AND THE INFORMATION CONTAINED HEREIN IS MADE AVAILABLE BY AUTODESK, INC. "AS IS." AUTODESK, INC., DISCLAIMS ALL WARRANTIES, EITHER EXPRESS OR IMPLIED, INCLUDING BUT NOT LIMITED TO ANY IMPLIED WARRANTIES OF MERCHANTABILITY OR FITNESS FOR A PARTICULAR PURPOSE REGARDING THESE MATERIALS.

Published by:

Autodesk, Inc.  
111 McInnis Parkway  
San Rafael, CA 94903, USA

# Contents

- Chapter 1    Installation. . . . . 1**
  - Contents of the AutoSketch Package . . . . . 2
  - System Requirements . . . . . 2
  - Install AutoSketch . . . . . 3
  - Register AutoSketch . . . . . 3
  - Repair AutoSketch . . . . . 4
  - Uninstall AutoSketch . . . . . 4
  
- Chapter 2    Make the Transition from Paper to CAD . . . . . 7**
  - Draw to Scale . . . . . 8
  - Organize Drawing Information . . . . . 9
  - Draw Efficiently . . . . . 10
  - Draw Accurately . . . . . 11
  - View Your Drawing . . . . . 12
  - Modify Your Drawing . . . . . 13
  - Use Standard Symbols . . . . . 14
  - Create Dimensions and Text . . . . . 15

<b>Chapter 3</b>	<b>AutoSketch Basics</b>	<b>17</b>
	Introduction	18
	Start AutoSketch	18
	Use the Start Up Dialog Box to Create or Open a Drawing.	18
	Start a Drawing or Choose a Wizard (Wizard Tab)	19
	Choose a Template (Template Tab)	21
	Open an Existing Drawing (Open Tab)	22
	Understand the User Interface	23
	Drawing Window.	23
	All-In-One Toolbar	25
	Content Librarian	28
	Edit Bar	28
	Menu Bar	28
	Property Bar	29
	Status Bar	29
	Title Bar.	30
	Toolbars.	30
	Tooltips	30
	Basic Features and Functionality	31
	Entities	32
	Properties	33
	Scale	34
	Coordinates	34
	Drawing Origin	35
	Reference Grid.	36
	Grid Origin.	37
	Snap	37
	Lock Modifier	38
	<b>Appendix — Drawings Created with AutoSketch</b>	<b>39</b>

# Installation

This chapter tells you how to install AutoSketch® on your computer. After you install the software, view the *Readme* (click Read Me on the Help menu). The *Readme* contains important information that was compiled after this guide was printed.

For step-by-step instructions about learning the product, read the entire *Getting Started* guide. You can find a PDF version of this guide in the following location (“C” is the installation drive letter):

*C:\Program Files\Autodesk\AutoSketch10*



## In this chapter

- Contents of the AutoSketch Package
- System Requirements
- Install AutoSketch
- Register AutoSketch
- Repair AutoSketch
- Repair AutoSketch
- Uninstall AutoSketch

# Contents of the AutoSketch Package

AutoSketch includes the following:

- AutoSketch disc
- AutoSketch *Getting Started* (this guide)
- Create and Trim Entities (online tutorial)
- Create a Birdhouse Drawing (online tutorial)
- Create and Office Layout Drawing (online tutorial)
- Advanced Exercises (online tutorial)

## System Requirements

Before you install AutoSketch, make sure that your computer meets the minimum system requirements.

Hardware and software requirements		
Hardware/Software	Requirement	Notes
Operating system	Windows®Vista or Windows®XP Service Pack 2, 32-bit	
Web browser	Microsoft®Internet Explorer 6.0 with Service Pack 1 (or later)	
Processor	Intel®Pentium®IV or AMD Athlon™2.2 GHz or greater	
RAM	Windows Vista - 1 GB Windows XP - 512 MB	
Video	800 x 600 (minimum) with True Color	Requires a Windows-supported display adapter
Hard disk	200 MB	
Pointing device	Mouse, trackball, or other compatible pointing device	
CD-ROM or DVD drive	Any speed (for installation only)	

# Install AutoSketch

This section explains how to install AutoSketch on a stand-alone computer.

## To install AutoSketch

- 1 Insert the AutoSketch CD into your CD-ROM drive.
- 2 Follow the installation prompts that are displayed.

If installation did not begin when you inserted the AutoSketch CD into your CD-ROM drive, Autorun may be turned off on your machine.

## To install AutoSketch if Autorun is turned off

- 1 Insert the AutoSketch CD into your CD-ROM drive.
- 2 On the Start menu (Windows), click Run.
- 3 In the Run dialog box, enter <*CD drive letter*>:\Setup.exe and click OK.
- 4 Follow the installation prompts.

Congratulations! You have successfully installed AutoSketch. You are now ready to register your product and start using the program.

# Register AutoSketch

Registering AutoSketch makes you eligible for technical support and for early notification of new product releases.

## To register AutoSketch

- 1 On the Start menu (Windows), click All Programs (or Programs) ► Autodesk AutoSketch 10.
- 2 In the AutoSketch Product Registration wizard, select Register Now, and then click Next.
- 3 Follow the on-screen instructions.

# Repair AutoSketch

If you accidentally delete or alter files that are required by AutoSketch, it might not perform correctly. You can attempt to repair AutoSketch.

## To repair AutoSketch

- 1 In the Control Panel (Windows), start Add or Remove Programs.
- 2 In the Add or Remove Programs window, select AutoSketch Release 10, and then click Change.
- 3 In the Setup wizard, Application Maintenance page, select the Repair option, and then click Next.
- 4 On the Ready to Repair the Application page, click Finish.
- 5 If prompted, restart your computer.

# Uninstall AutoSketch

When you uninstall AutoSketch, all components are removed from the computer.

---

**Note** Uninstalling the application does not automatically delete drawing files you have created. You can delete those files manually.

---

## To uninstall AutoSketch

- 1 In the Control Panel (Windows), start Add or Remove Programs.
- 2 In the Add or Remove Programs window, select AutoSketch Release10, and then click Remove.
- 3 In the message box that is displayed, click Yes to remove AutoSketch.
- 4 If prompted, restart your computer.





# Make the Transition from Paper to CAD

With your decision to use AutoSketch®, you have entered the world of computer-aided design (CAD). AutoSketch makes your drawings more precise and you more productive than you have been using paper as your design format.

This chapter explains how you can take your drafting knowledge and apply it to CAD.

# 2

## In this chapter

- Draw to Scale
- Organize Drawing Information
- Draw Efficiently
- Draw Accurately
- View Your Drawing
- Modify Your Drawing
- Create Dimensions and Text

# Draw to Scale

Drawing scale is something you consider when laying out your drawing. You establish scale differently in CAD than you do with manual drafting.

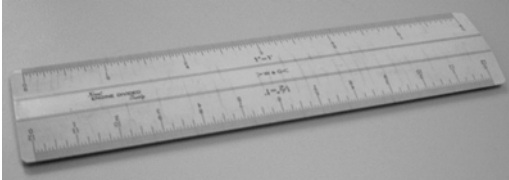

Draw the object at full scale in the units you specify.

With manual drafting, you must determine the scale of a view before you start drawing. This scale compares the size of the actual object to the size of the object drawn on paper.

In AutoSketch, drawings are created using the real-world values you specify. The computer handles scaling the drawing to fit on paper.

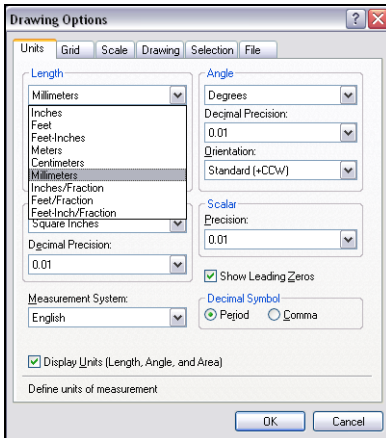

When you lay out and plot your drawing, you can set any scale you like.

For example, you can use feet and inches, or meters and kilometers, and so on. You might draw a motor part with millimeters as the unit of length so that entering **25** means “25 millimeters.” When you draw a map, you might select kilometers so that entering **25** means “25 kilometers.”

Although you can easily change scaling at any point while drawing, it is useful at the start to select a scale that is appropriate to the drawing you are working on. This allows you to keep your drawing on the “page” that AutoSketch displays on screen.

# Organize Drawing Information

In both manual drafting and CAD, you need a way to organize your drawing content—a method for separating, sorting, and editing specific drawing data.

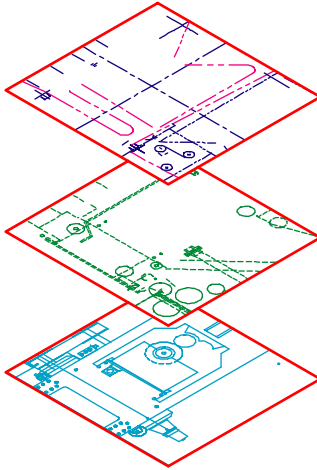

Turn off layers to hide complex details as you work.

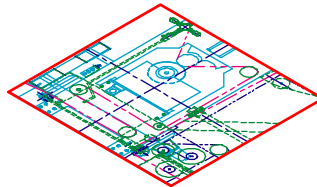

Display layers when you need to see all components.

With manual drafting, you can separate information onto individual transparent overlays. For example, a building plan might contain separate overlays for its structural, electrical, and plumbing components.

In AutoSketch, *layers* are equivalent to transparent overlays. As with overlays, you can display, edit, and print layers separately or in combination.

You can name layers to help track content, and lock layers so they can't be altered. Assigning settings such as color, pen style, or pen width to layers helps you comply with industry standards.

You can also use layers to organize drawing objects (called *entities* in AutoSketch) for printing.

This mechanical drawing of a press uses layers to show different types of information in different styles and colors.

# Draw Efficiently

Draw with less effort and revise with more speed: these are the two main reasons you use CAD. AutoSketch has a complete set of drawing and editing tools to help eliminate repetitive, time-consuming drafting tasks.



If you work with paper and a drawing board, your set of drawing tools is likely to include pencils, scales, parallel rules, templates, and erasers. Repetitive drawing and editing tasks must be done manually.

In AutoSketch, you can choose from a variety of drawing tools that create lines, rectangles, circles, curves, and more.

With AutoSketch, you can easily copy, scale, rotate, and mirror entities. You can move or copy entities between open drawings or within the same drawing. Editing is easy with tools such as stretch, align, and offset. To add hatching, simply insert a hatch pattern from the AutoSketch *Content Librarian* into the area to be filled.

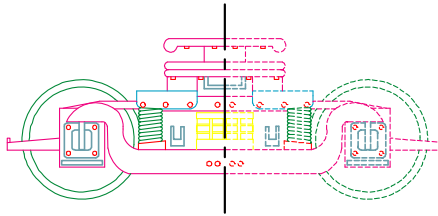

You can save drafting time by drawing one half of an item and then mirroring it to create the other half.

In this drawing of a trolley, copying and mirroring were used to create repeated and symmetrical features. Offsetting lines and hatching were also used to draw more efficiently.

# Draw Accurately

Engineering and architectural drawing require a high degree of accuracy. With CAD, you draft more accurately than with manual methods.

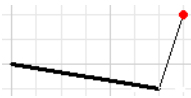

Snaps allows you to draw with precision.

On paper, you must draw objects carefully to ensure correct size and alignment. Objects drawn to scale must be manually verified and dimensioned.

In AutoSketch, you can ensure exact dimensions by using several methods. The simplest method is to locate points by snapping to some interval of a *grid*.

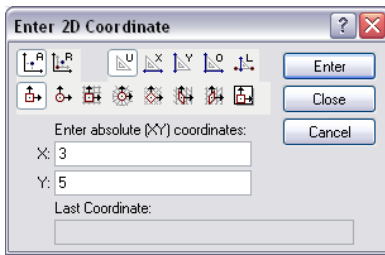

Another method is to specify exact *coordinates*. Coordinates specify a drawing location by indicating a point along an X and Y axis or a distance and angle from another point. You can specify coordinates that are relative to other points or to the drawing's coordinate system.

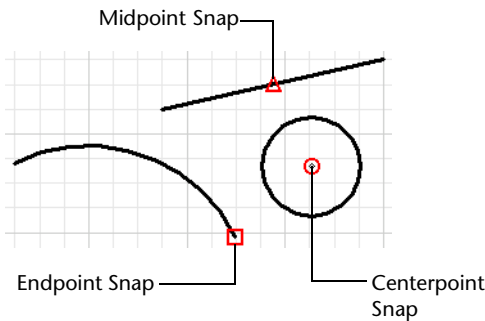

You can also snap to locations on existing entities, such as an endpoint of an arc, the midpoint of a line, or the centerpoint of a circle.

# View Your Drawing

The power of CAD makes it easy for you to quickly view different parts of your design at different magnifications.

When you draft on paper and need to work on another section, you must physically move to that area of your drawing.

In CAD, the size and resolution of your computer monitor limit your viewing area. AutoSketch viewing methods bypass this limitation.

To do detailed work, you can increase display size by *zooming in*. You can zoom out to display more of the drawing. To move to another section of a drawing, you *pan* the drawing without changing magnification.



You can view several areas of your drawing simultaneously by creating additional *windows*. Windows can be arranged automatically or manually. They let you work easily on different parts of your drawing. Changes in one window are reflected in the others.

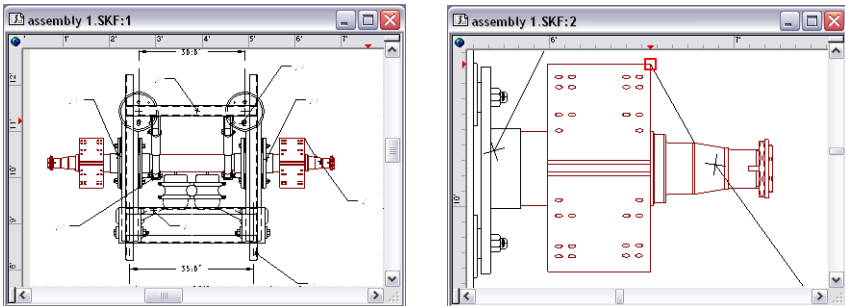

Windows display different portions of your drawing simultaneously. You can zoom and pan the display in each window independently.

With *detail views*, you can arrange additional views at different zoom levels or scales. You can create split windows, and you can pan and zoom in each window to create the best working conditions.

# Modify Your Drawing

Revisions are a part of any drawing project. Whether you work on paper or with CAD, you will need to modify your drawing in some way.



If you stretch an entity...



...the hatch adjusts automatically.

On paper, you must manually erase and redraw to make revisions to your drawing.

AutoSketch eliminates tedious manual editing by providing a wealth of editing tools. If you need to copy all or part of an entity, you don't have to redraw it. If you need to remove an entity, you can erase it with a few clicks of the mouse. And if you make an error, you can quickly undo your actions.

Once you draw an entity, you never need to redraw it. You can modify existing entities by mirroring, rotating, scaling, stretching, trimming, and more. At any time, you can change entity properties, such as pen style, pen width, color, and layer.

These before-and-after drawings show some typical edits to a house elevation.

# Use Standard Symbols

Symbols have long been used in manual drafting as a way to represent real-world objects in a simplified way. The ability to create and reuse standard symbols is one of CAD's greatest strengths.

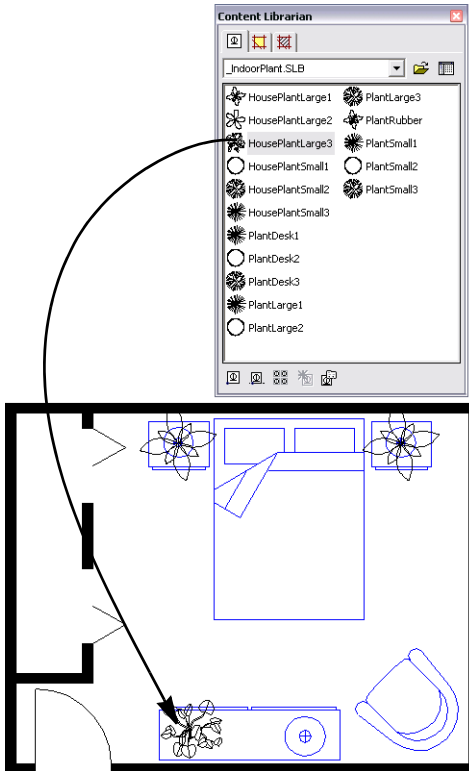

The Content Librarian lets you locate libraries (collections) of symbols. You choose the symbol you want and drag it into your drawing.

With manual drafting, you might use a symbol template or printed stickers to draw repetitive landscape, architectural, mechanical, or electrical symbols. This method, however, limits the possible variations of a symbol.

In AutoSketch, you can save time by inserting symbols from the Content Librarian anywhere in your drawing, at any rotation or scale.

You can then add a symbol as many times as needed by simply clicking to place the symbol.

Should a standard symbol change (be *redefined*), all instances of the symbol in your drawing will automatically be replaced.

In AutoSketch, you can also create your own symbols from scratch or modify existing ones.

Standard landscaping symbols are used in this drawing of a residential home floor plan.

# Create Dimensions and Text

Creating accurate dimensions and consistent, legible text is a time-consuming task for the manual drafter. CAD provides ways to streamline this task.

When you work on paper, you typically draw to scale and then add dimensions and annotations. If you resize any part of the drawing, you must erase and then redraw the dimensions. Changing text can often involve relettering the whole drawing. AutoSketch automates the process of creating and changing dimensions and text.

In AutoSketch, you can customize individual dimensions, and when information changes, you can easily revise text, including its content, font, height, angle, and justification.

Virtually all standard dimensioning types are provided in AutoSketch: linear, radial, ordinate, angular, base-line, and more.

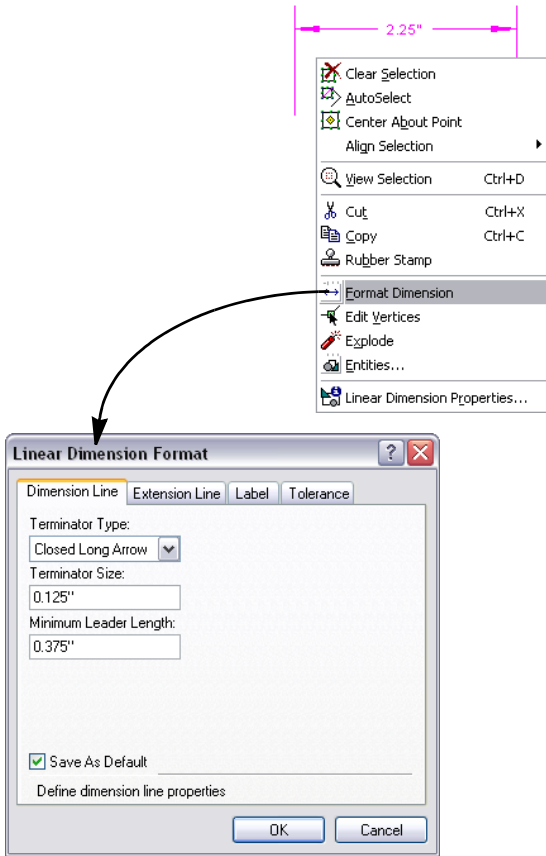



# AutoSketch Basics

# 3

In this chapter, you learn how to start AutoSketch® and use the Startup dialog box to create or open a drawing. You also learn about the user interface and the basic features and functionality of AutoSketch. Once you have learned these AutoSketch “basics,” you can do the exercises in this guide’s tutorials and learn to use the product.

More information about each of these components and features is available in the Help system.

## In this chapter

- Introduction
- Start AutoSketch
- Use the Start Up Dialog Box to Create or Open a Drawing
- Understand the User Interface
- Basic Features and Functionality

# Introduction

AutoSketch is a precision drawing tool for the Microsoft® Windows® XP and Windows® Vista operating systems. The emphasis in AutoSketch is on speed, power, and ease of use.

AutoSketch features appear when you need them, and are kept out of the way when you don't. If you're already a Windows Vista or Windows XP user, you'll find the menu system and much of the user interface familiar. If you're new to Windows, you'll find AutoSketch an easy place to work.

In this chapter, you learn how to start AutoSketch and use the Start Up dialog box to create or open a drawing, and you get familiar with the user interface components.

## Start AutoSketch

When you start AutoSketch, you can begin a new drawing, start with a template, or open existing drawings. Simply click a selection and begin.

### To start AutoSketch for the first time

- On the Start menu (Windows), click All Programs (or Programs) ► Autodesk AutoSketch 10.

The AutoSketch Start Up dialog box is displayed.

## Use the Start Up Dialog Box to Create or Open a Drawing

The Start Up dialog box has three tabs with options for starting a drawing:

- **Wizard tab.** Allows you to start a drawing immediately or choose one of the listed wizards.
- **Template tab.** Allows you to base a drawing on a template, and to preview and organize the templates.
- **Open tab.** Allows you to open a recently used file, browse for a file, and preview a selected file.

## Start a Drawing or Choose a Wizard (Wizard Tab)

In the Start Up dialog box, Wizard tab, you can start a drawing immediately or choose a wizard to start a drawing.

A wizard contains instructions to guide you through the steps to accomplish a task. The AutoSketch Start Up wizards help you make drawing decisions to set up a drawing. If you are drawing a workbench project, for example, the wizard steps you through logical workbench decisions for that drawing.

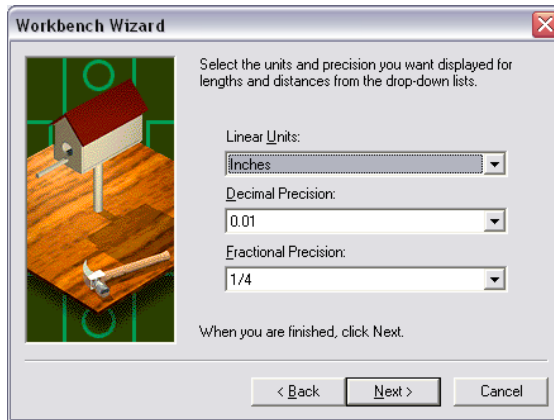

Example of a page in the Workbench wizard

---

**Tip** During an AutoSketch work session, you can access wizards by clicking File ► New.

---

The illustration shows the Wizard tab, and is followed by an explanation of each of its choices.

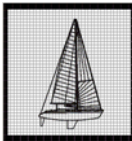
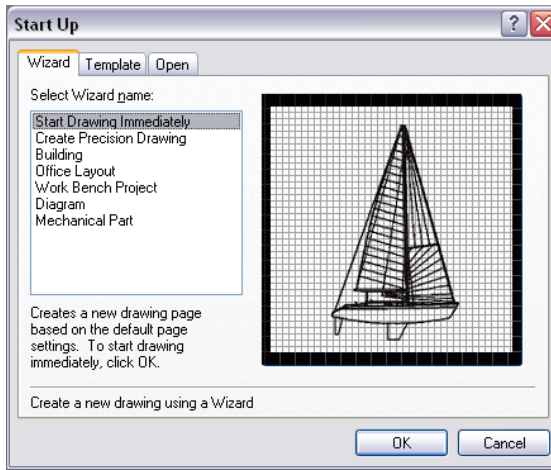

**Start a Drawing Immediately.** Creates a new drawing based on preset settings such as page size and scale. You can always change these settings later. Select this option, and then click OK. You are ready to begin drawing.

The following choices on the tab are wizards:



**Create Precision Drawing.** Creates a new drawing based on settings that you specify. You enter summary information (including drawing title, project name, and so on), drawing size and scale, units of measurement, and grid spacing



**Building.** Sets up a drawing of a commercial building, home, or exterior site layout. You choose the building shell, dimensions, wall thickness, roof generation, database report types and fields, layers, page orientation, and useful toolbars. You can add symbols such as telephone poles, trees, and hydrants.



**Office Layout.** Sets up a drawing of a single office or an entire floor of offices. You choose the office shell, dimensions, wall thickness, database report types and fields, layers, page orientation, grid settings, and useful toolbars. You can add symbols such as telephones and computer equipment.



**Work Bench Project.** Sets up a drawing of a small home, or a mechanical or woodworking project. You specify page orientation, units and precision, scale, grid options, database report types and fields, layers, and useful toolbars.

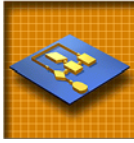

**Diagram.** Sets up a diagram such as organizational tree, Web site map, flow chart/schedule, piping, electronic schematic, logic diagram, networking, or PC board layout. You choose the type of diagram, page orientation, and useful toolbars.

You can add symbols such as flowcharts, schedules, piping, switches, capacitors, lamps, switchboxes, PCs, printers, main-frames, modems, circuit chips, soldering points, and so on.

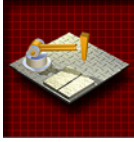

**Mechanical Part.** Sets up a drawing of a small machine or machine component. You specify page orientation, units, precision, scale, annotation options, Edit command settings, grid options, page division (for different views of a part), database reports and fields, layers, and useful toolbars. You can add symbols such as nuts, bolts, screws, brackets, washers, and so on.

## Choose a Template (Template Tab)

In the Start Up dialog box, Template tab, you can choose a template file to start a drawing.

AutoSketch includes dozens of drawing template files. A template is a drawing file that has settings such as borders, title blocks, grid spacing, drawing scale, and page size already selected for you. When you select one of the templates in the list, you can preview it in the Preview area. Then, you simply choose the template that is right for your project.

You can also create your own template from an existing drawing. If you create the same type of drawing each time you work with AutoSketch, you may want to redefine the default template by saving an existing drawing as a template, and then selecting that template as the new default. Then, you can use the template to create new drawings of the same type.

The following illustration shows the Template tab.

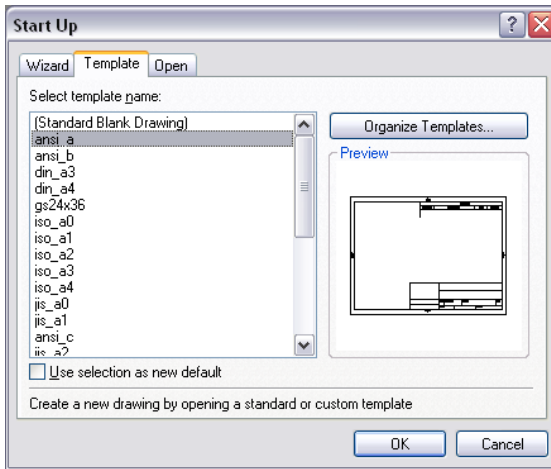

**Tip** During an AutoSketch work session, you can access templates by clicking File ► New.

## Open an Existing Drawing (Open Tab)

In the Start Up dialog box, Open tab, you can open an existing drawing file. You can adjust how files are displayed in the list, browse for more files, and preview a selected file.

The following illustration shows the Open tab.

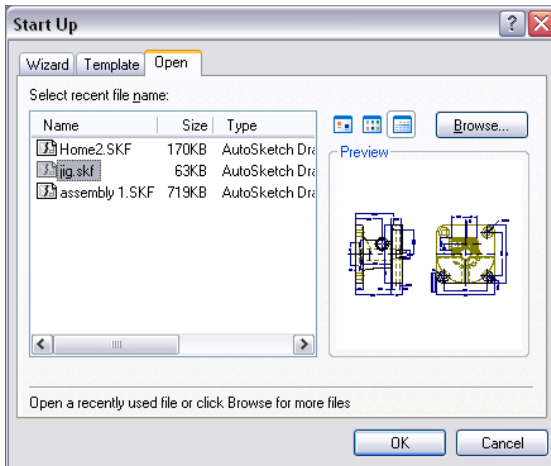

---

**Tip** During an AutoSketch work session, you can access existing drawings by clicking File ► Open.

---

## Understand the User Interface

The first step in learning how to use AutoSketch is to become familiar with its user interface.

### Drawing Window

Once you choose the type of drawing you want to create, AutoSketch opens a drawing window. The drawing window in AutoSketch is the space where you work.





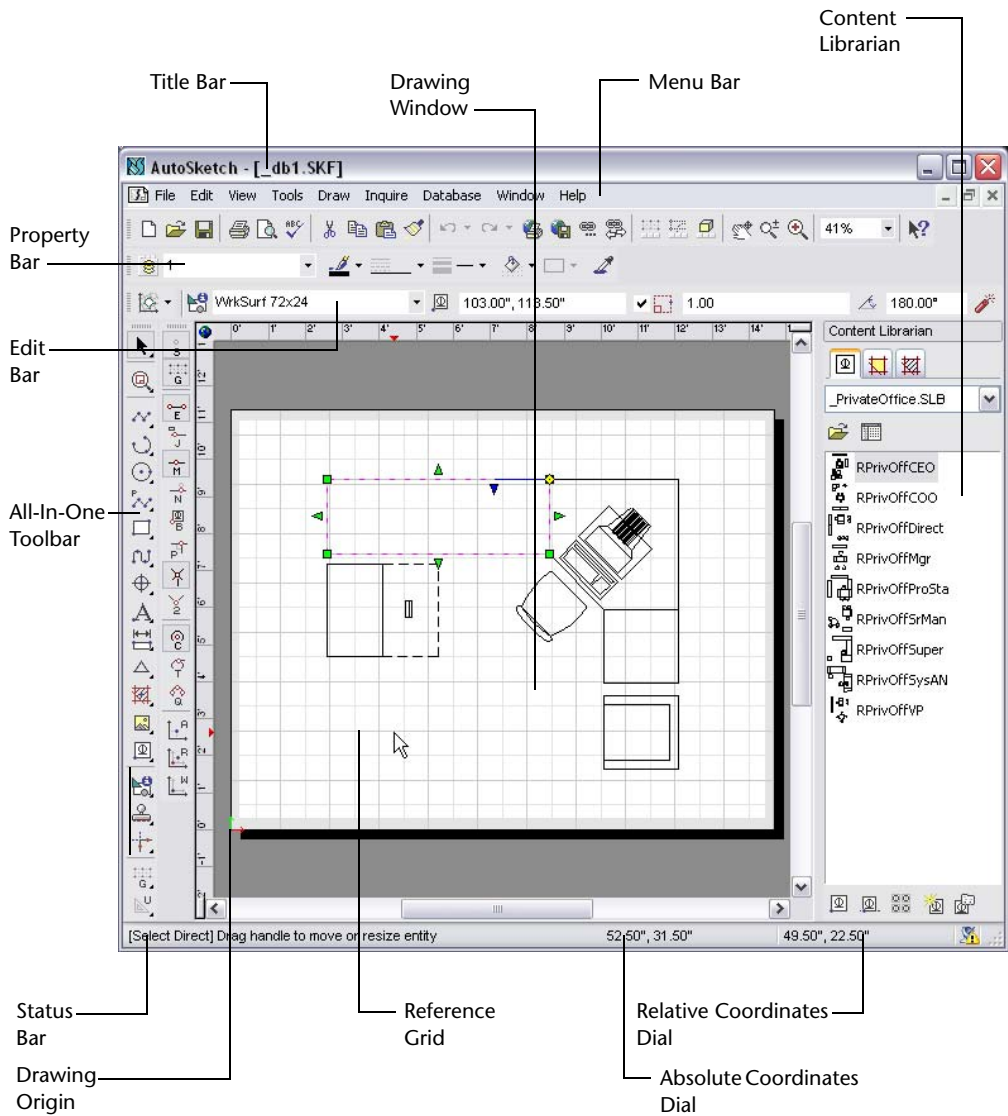





Many drawing windows can be open at one time. Clicking a drawing window makes it active so that you can work in it. You can make changes in the active window only. You can resize, minimize, maximize, and close each drawing window independently.

The following illustration shows the AutoSketch user interface elements in a drawing window. These elements are listed alphabetically and described after the illustration.













## All-In-One Toolbar buttons (continued)

Toolbar button	Button name	Description
	Line	Draws lines and line variations. The Line toolset has these buttons: Line Single; Line Segment; Line Multiple; Line Double; Line Tangent; Line Perpendicular; Line Angle.
	Arc	Draws circular arcs and elliptical arcs. The Arc toolset has these buttons: 3 Point Arc; 2 Points and Center Arc; 2 Points and Angle Arc; Elliptical Arc Rectangle; Elliptical Arc Axes.
	Circle	Draws circles and ellipses. The Circle toolset has these buttons: Center, Side Circle; Side, Side Circle; 3 Point Circle; Center, Radius Circle; Circle Tangent 2; Circle Tangent 3; Ellipse Rectangle; Ellipse Axes.
	Polyline	Draws polylines. The Polyline toolset has these buttons: Single Polyline; Polyline Segment; Perpendicular Polyline; Center Polyline; Sketch Polyline.
	Polygon	Draws polygons. The Polygon toolset has these buttons: Rectangle; Rotated Rectangle; Regular: Center, Edge; Regular: Edge, Opposite; Regular: Edge, Adjacent; Regular: Center, Radius; Irregular Polygon; Irregular Cloud.
	Curve	Draws fitted and spline curves. The Curve toolset has these buttons: Fitted Curve; Spline Curve.
	Marker	Marks points in your drawing. The Marker toolset has these buttons: Marker Point; Marker Align Entity; Marker Align Endpoint.
	Text	Enters a line or paragraph of text in your drawing. The Text toolset has these buttons: Text Point; Text Rectangle.
	Dimension	Draws dimension lines. The Dimension toolset has these buttons: Horizontal Dimension; Vertical Dimension; Rotated Dimension; Aligned Dimension; Angular Dimension; Radius Dimension; Diameter Dimension; Centerline Dimension; Ordinate Dimension; Leader.
	Duplicate	Creates a duplicate of a selected entity and places it at a specific offset distance. The Duplicate toolset has these buttons: Parallel; Offset.

## All-In-One Toolbar buttons (continued)

Toolbar button	Button name	Description
	Fill	Creates hatches (a repetitive line pattern in an enclosed area defined by a selection set). The Fill toolset has these buttons: Fill Hatch; Fill Solid Color.
	Picture/Detail View	Inserts bitmap pictures or detail views into the drawing. The Picture/Detail View toolset has these buttons: Picture From File; Detail View.
	Symbol	Manages, creates, places, and duplicates symbols in a drawing. The Symbol toolset has these buttons: Symbol Point; Insert Symbol; Symbol Array; Create Symbol.
	Inquire	Displays information about a drawing and its entities. The Inquire toolset has these buttons: Inquire Entity; Inquire Symbol Count; Inquire Selection; Inquire Drawing; Inquire Coordinate; Inquire Distance; Inquire Angle; Inquire Area.
	Transform	Moves, scales, rubber-stamps, or rotates entities. The Transform toolset has these buttons: Rubber Stamp; Rubber Stamp Array; Translate; Scale; Rotate; Align; Mirror; Stretch; Rectangular Array; Circular Array.
	Trim	Edits the geometry of entities. The Trim toolset has these buttons: Trim Corner; Trim Round; Trim Bevel; Trim Edge; Trim Break; Trim Channel; Trim Divide; Trim Subdivide; Trim Join; Trim Alcove; Trim Union; Trim Intersection; Trim Difference
	Snap	Snaps to a point on the grid. The Snap toolset has these buttons: Snap Off; Gridpoint Snap; Endpoint Snap; Jump Snap; Midpoint Snap; Nearest Snap; Basepoint Snap; Perpendicular Snap; Intersection Snap; 2 Point Intersection; Centerpoint Snap; Tangent Snap; Quadrant Snap; Absolute Input; Relative Input; Set Last (Working) Point.
	Lock	Turns lock modification on and off. The Lock toolset has these buttons: Unlock; Lock X; Lock Y; Ortho Lock; Normal Lock.



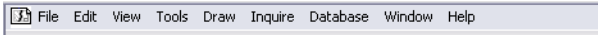

The menu bar

## Property Bar

Sets the current layer, color, style, width, and pattern. Any change you make on the property bar affects entities that are currently selected, and those that you draw in the future.



The property bar

To change a setting on the property bar, click the small arrow to display the list of properties, and make a new selection. To apply a new setting to an entity, select the entity you want to change, and then click the property setting on the property bar.

## Status Bar

Displays a message area on the left side and the coordinates dials on the right. The message area displays prompts, messages, and step-by-step instructions for most procedures.



The status bar

Two *dials* occupy the right side of the status bar. The Absolute Coordinates dial (on the left side) displays the absolute location of the point (its position in relation to the drawing origin). The Relative Coordinates dial (on the right side) displays the relative location of the point (its position in relation to the last point entered).

## Title Bar

Displays the name of the program and the name of the current drawing file. The AutoSketch title bar extends across the top of the application window.



The title bar

## Toolbars

Provide buttons that allow you to do drawing tasks. (You can also use menus to perform the same tasks.) When a toolbar button has a triangle in its lower-right corner, you can click and hold the button to access additional items, called *toolsets*.

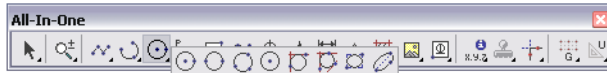

The All-In-One toolbar with the Circle toolset displayed

You can move a toolbar by clicking near its left edge and dragging it to its new location. You can also place toolbars next to one another and dock them in the drawing window.

## Tooltips

Display the name or the function of toolbar buttons. Hold your pointer over a tool to display its tooltip.



Example of a tooltip



To display a more detailed explanation of the tool, click the Help button (on the Standard toolbar), and then click a toolbar button.

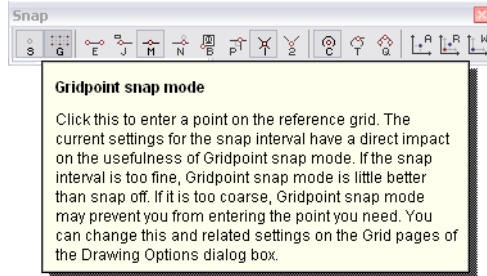

Example of detailed Help for a tool

## Basic Features and Functionality

Before you use AutoSketch, there are important features and functionality that you should understand. Understanding the concepts in the following sections is the key to a successful experience of doing this book's exercises. It is strongly recommended that you read this material carefully. Each concept is briefly defined here and described in detail afterward.

- **Entity.** A single object, such as a line, polygon, or symbol.
- **Properties.** An item of information assigned to an entity. Properties include geometry, layer, pen, pattern, and so on.
- **Scale.** The ratio between the size of an entity in its scaled output and the size of the real-world object it represents. For example, if an entity that is 1/4 inch long in its scaled output represents a real-world object that is 1 foot long, the drawing scale is  $1/4"=1'0"$ .
- **Coordinates.** A pair of numbers that together specify the location of a point in your drawing.
- **Drawing Origin.** The point that serves as a location reference for all entities in the drawing. The x- and y-axes cross at the drawing origin. The coordinates of the drawing origin are 0,0.
- **Reference Grid.** An on-screen drawing aid consisting of a snap grid and a pattern of lines, crosses, or dots that visually represent the grid.
- **Grid Origin.** The point from which the axes of the reference grid extend outward.
- **Snap.** A means of entering points using the mouse or keyboard. You can change the snap at any time during most Draw and Edit operations by typing the appropriate keyboard shortcut.
- **Lock Modifiers.** Four modifications that you can apply to a snap. Lock modifiers align input with the last point and are applied after the snap.

For detailed information about these concepts, see the Help system.

## Entities

Entities are the fundamental elements of a drawing. They can be simple (*base* entities), such as a single line, arc, circle, or polyline, or they can be groups of drawing elements (*compound* entities), such as symbols and dimensions. Entities can also be other elements in your drawing, such as pictures or elements from other drawings. Most entities can be edited. You can resize them and change their properties.

The following table lists the type of entities that you can create in AutoSketch.

Entity	Description
Arc	A portion of a circle. You can use an arc to show a rounded wall, the direction a door swings, and so on.
Circle	A curved line with every point equally distant from the center. You can use a circle to represent a hole, a round object, and so on.
Curve	A polyline that is rendered onscreen and on printed output in a special way. Use curves to create free-form shapes such as curved sidewalks and car fenders.
Detail view	A rectangular area that displays another portion of the drawing defined by a previously saved view.
Dimension	A predefined collection of lines, arcs, markers, and text that display a measurement in the drawing. The text label is updated automatically when you stretch or reshape the dimension.
Ellipse	A closed symmetrical curve that resembles a flattened circle.
Fill	A hidden-line polygon that conforms to the shape of a bounded area and displays either a solid color, a hatch, or a bitmap fill.
Group	A compound entity consisting of individual symbols and entities that AutoSketch treats as a single entity.
Line	An entity that connects two points. You can use a line to represent any straight object such as a water pipe, a wall edge, an electrical connection, or a street.
Marker	An entity that notes a specific point in a drawing.

Entity	Description
OLE Object	An entity that is created in one application and embedded in another. When you double-click a linked OLE object, Windows opens the source application that created it and loads the associated file.
Picture	A picture or bitmap that can be imported and placed in the drawing. AutoSketch treats the raster image like most other entities, allowing you to move, scale, or duplicate the image as needed.
Polygon	A closed polyline that can contain a fill pattern. Use a polygon when you need to know the area of an enclosed region or when you need to fill an area with a solid color, a hatch, or a bitmap fill.
Polyline	A multi-segmented line that AutoSketch treats as a single entity. When a polyline is closed, it becomes a polygon. Use a polyline when you need to know the total length of a series of connected segments.
Symbol	A group of entities that AutoSketch treats as a single entity. Symbols can be stored in libraries for use in multiple drawings.
Text	A text entity that can be any size, can use any TrueType font, and can be rotated at any angle.

## Properties

Properties are the individual qualities that define an entity. They are divided into three categories:

- **Geometric properties** define an entity's size, position, and so on. AutoSketch assigns geometric properties automatically as you draw and edit.
- **Graphic properties** specify the appearance of an entity. Graphic properties include layer, color, width, style, and pattern. AutoSketch assigns these properties as you draw, based on the current settings on the property bar.
- **Fields** customize an entity in ways that you define. Define a field by specifying its name, type, and width or precision. A desk symbol, for example, can have fields for model, size, color, and style.

## Scale

Drawing scale is the ratio between the actual size of the entities in a drawing and their size on printed output. In conventional drafting, you scale the components of a drawing by using an architectural or engineering scale. In AutoSketch, you simply enter the actual (world) size of an entity, and the software keeps track of the scale for you.

You can create 1:1 drawings in AutoSketch without regard for scale. Specifying a drawing scale, however, has two important benefits. It allows AutoSketch to accurately depict how your drawing will look on a printed page. It also allows you to specify entities such as text, markers, and dimensions by output size.

Any output you plan to measure with an architectural or engineering scale must be printed to scale. When you create scaled output, you can print the entire drawing or a portion of the drawing. The scale used when printing is the current drawing scale.

## Coordinates

Coordinates are numbers that specify the location of one point in relation to another. This relationship is classified as either absolute or relative.

Absolute coordinates reference the origin of whatever coordinate system is currently being used (for example, the drawing origin or the grid origin).

Relative coordinates reference the last point you entered. They are useful when you want to draw or place another entity a known distance from another entity or point.

AutoSketch expresses location in three ways: xy (Cartesian), polar, and isometric coordinates. X- and y-coordinates express location in terms of horizontal and vertical distances from another point. Polar coordinates express location in terms of distance (radius) and angle. For example, the xy coordinates 7,5 are equivalent to the polar coordinates 8.6,35.5.

Isometric coordinates add a third axis (z) to the expression. Isometric drawings are often used to create two-dimensional views of a three-dimensional object.

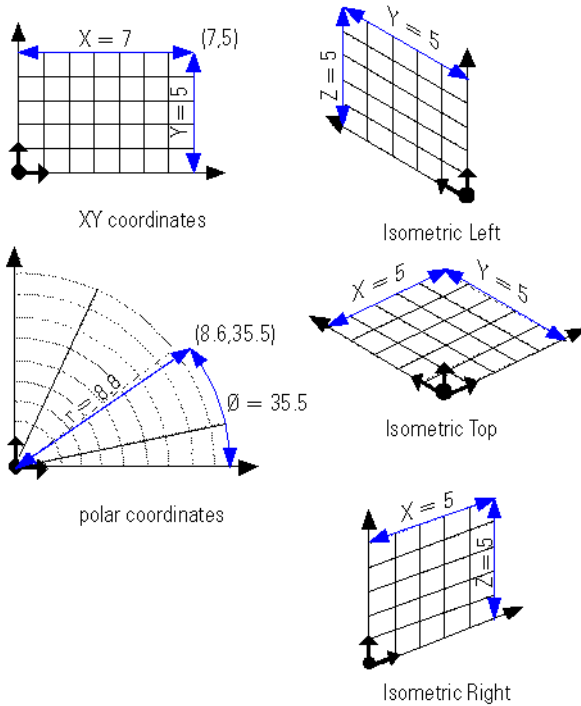

### Examples of coordinates

## Drawing Origin

The drawing origin displays the  $x$  (horizontal),  $y$  (vertical), and (if isometric)  $z$  coordinates of a drawing. AutoSketch locates most points in relation to the drawing origin.

The drawing origin is shown on screen as colored arrows.

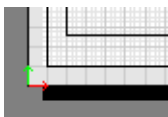

### Example of the drawing origin arrows in the lower-left corner of a drawing

If you move the drawing origin, the entire drawing shifts to reflect that change. The drawing origin does not appear when you print the drawing. Normally, the drawing origin is located at the lower-left corner of a drawing. If you need to move it, you can center the drawing origin or relocate it.

## Reference Grid

A reference grid is a visual drawing aid that contains a pattern of horizontal and vertical lines or dots that represent a grid. Use gridpoint snaps to make your drawing precise.

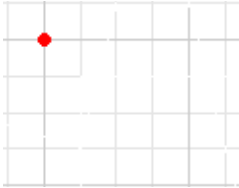



### Example of a first point snapping to a grid





There are three types of reference grids available in AutoSketch, each suited for different purposes.

- The default grid is *rectangular*, with snap intervals and lines that parallel the x- and y-axes. This grid is the standard reference tool for most two-dimensional drawings.
- *Circular* grids extend radially from the grid origin. They provide an excellent reference tool for drawings that require alignment of points along an arc or circle, such as a mechanical drawing of a gear.
- *Isometric* grids align along three major axes, instead of two. This allows you to create two-dimensional drawings of three-dimensional objects.

You can modify the settings for each of the reference grids.

The following table lists the Grid tools you can use in AutoSketch. These buttons are located on the Grid toolbar.

Toolbar button	Button name	Description
	Rectangular	The most commonly used, is useful for most two-dimensional drawings.
	Circular	Aligns grid lines along an arc or circle. The radial grid lines allow you to enter such points precisely. When you set up a circular grid, you may need to reposition the grid origin so that the radial lines of the grid are aligned correctly on the page.
	Isometric Top	Aligns snap and grid lines along 30- and 150-degree axes.

Toolbar button	Button name	Description
	Isometric Left	Aligns snap and grid lines along 90- and 150-degree axes.
	Isometric Right	Aligns snap and grid lines along 90- and 30-degree axes.
	Double Grid Size	Doubles the current grid size.
	Halve Grid Size	Decreases the current grid size by half.

**Tip** You can also change settings using the Edit Grid button on the Standard toolbar.

## Grid Origin

The grid origin is similar to the drawing origin in function and appearance. However, the grid origin serves as a reference point for grid coordinates only. By default, the grid origin is located at the drawing coordinates 0,0. You can move the grid origin of rectangular, circular, or isometric reference grids.

## Snap

Using snap, you can draw with real precision by identifying exact points such as an entity's midpoint, endpoint, or centerpoint. These points are called snap points because when you click near one, the point is snapped to the exact point shown.

There are 15 ways to snap to a point in AutoSketch. These correspond with the 15 snaps you can choose by clicking their buttons on the All-In-One toolbar, Snap toolbar, or by typing the letter shown on the button.

When snaps are active, a red AutoPoint Indicator is displayed on the grid. As you move the pointer over a drawing, each type of snap point displays a different symbol. (You may notice these snap types when you create simple entities in the first tutorial.) The following table lists the default snap types.

Symbol	Snap Type	Description
●	Gridpoint snap	Snaps to the reference grid.
□	Endpoint snap	Snaps to the endpoint of an entity.
△	Midpoint snap	Snaps to the midpoint of a line, polyline segment, etc.
×	Intersection snap	Snaps to intersection points.
○	Centerpoint snap	Snaps to the center of an arc, circle, polygon, or bulged poly-segment.

## Lock Modifier

You can align input with the last point by using a lock modifier. If a lock modifier is active, a dotted line extends from the AutoPoint Indicator to the actual point, as constrained by the lock modifier. For example, if you draw a diagonal line from top to bottom, and then activate Endpoint snap and the Y-axis lock modifier, the square AutoPoint Indicator identifies the endpoint nearest the pointer, but a dotted line extends to the potential snap point based on the current snap and lock modifier.

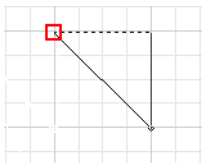

### Example of a line drawn with endpoint snap and y-axis lock modifier turned on

There are four automatic modifications you can have AutoSketch make to the point you enter. These lock modifiers force the point you enter into horizontal, vertical, orthogonal, or “normal” alignment with the last point. At any time in the drawing or editing process, you can apply a lock modifier by clicking its button on the All-In-One toolbar or by typing the letter shown on the button.

# **Appendix — Drawings Created with AutoSketch**

This appendix contains several drawings that were created with AutoSketch®. Study these drawings to get ideas for your own drawings, or just to see the power of the product.

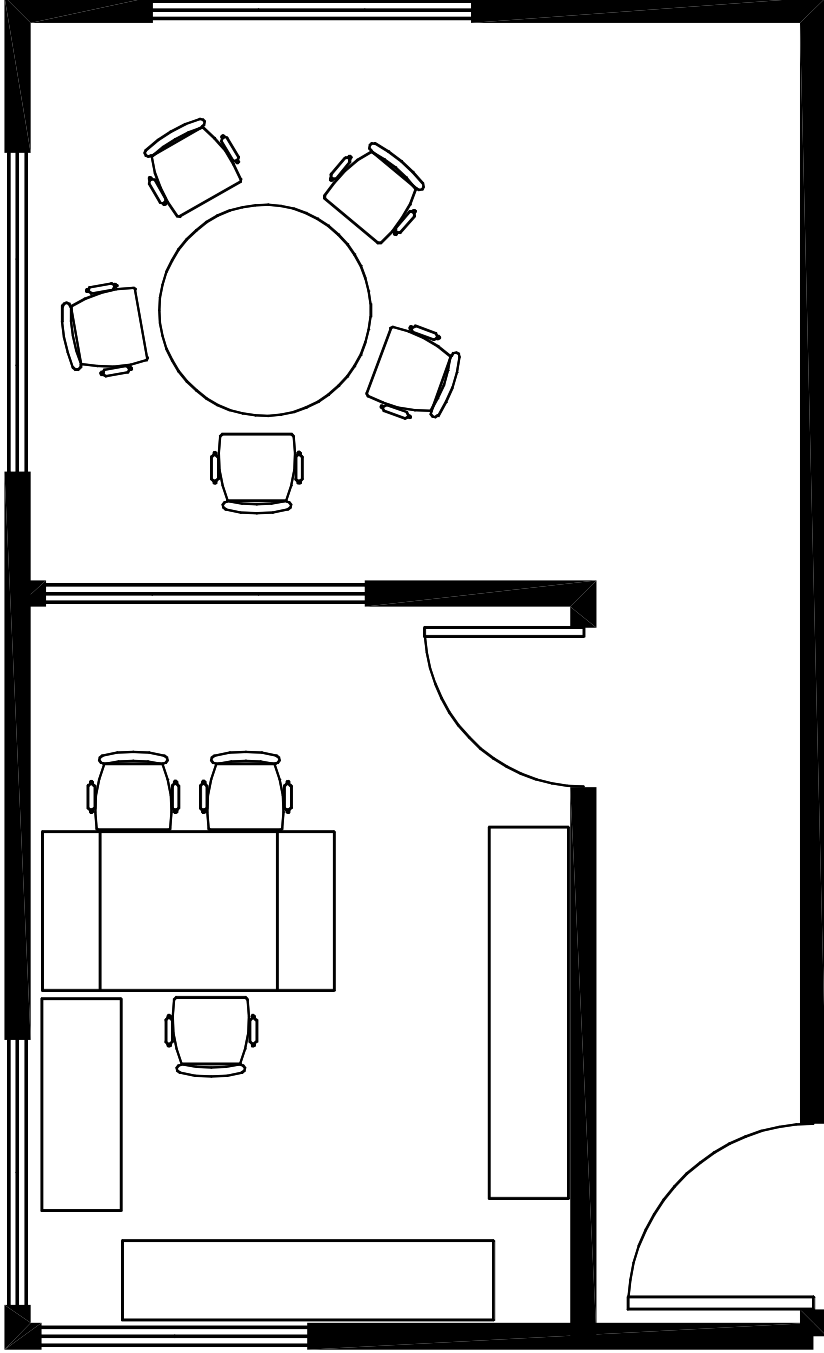

Office – created using the Office Layout wizard

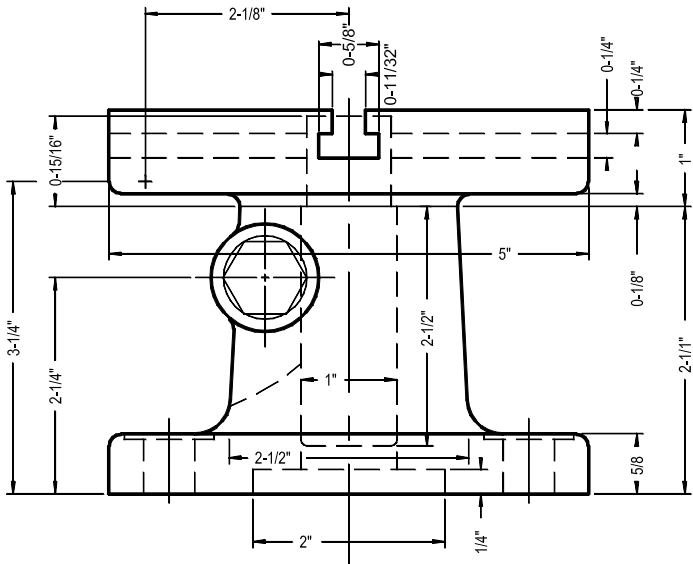
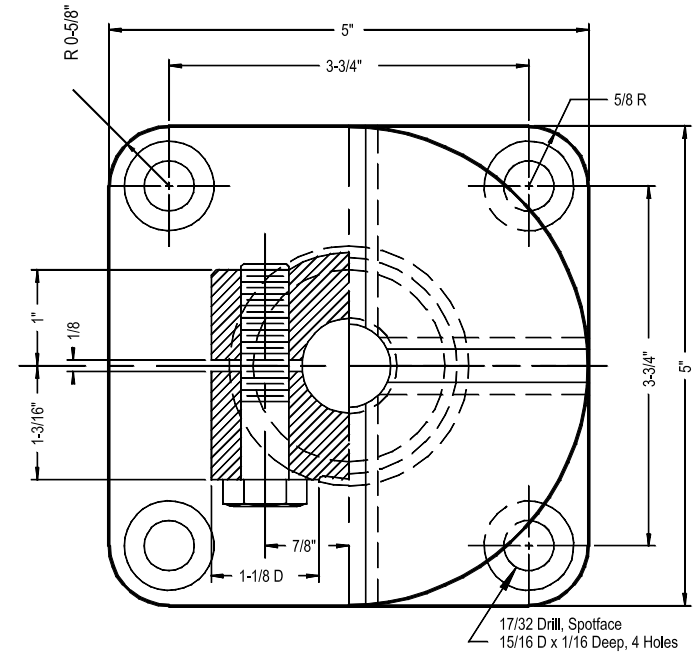

Jig – created using the Mechanical Part wizard

**NOTES:**  
Refer to Specifications Document

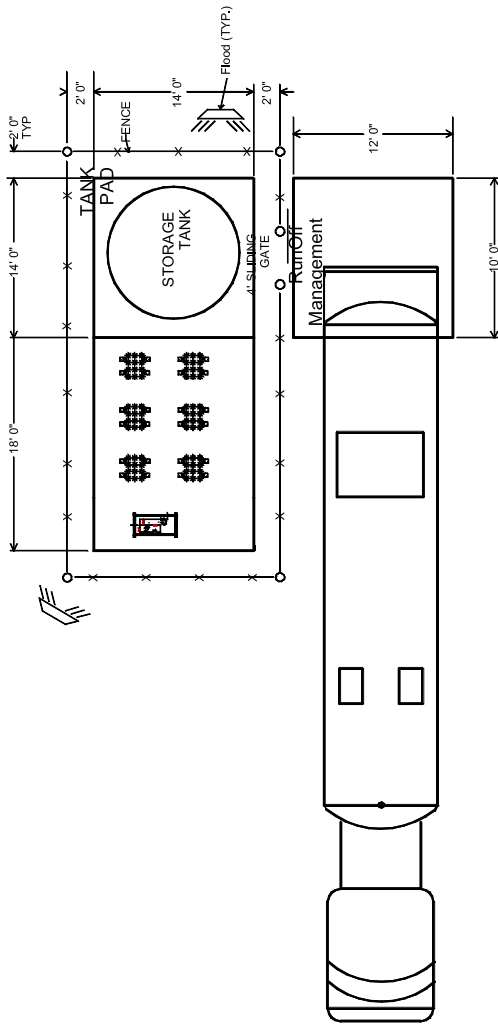

**PAD DETAIL WITH RUNOFF**

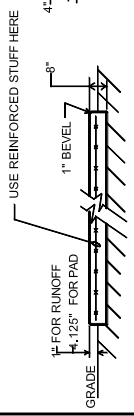

**PAD DETAIL**

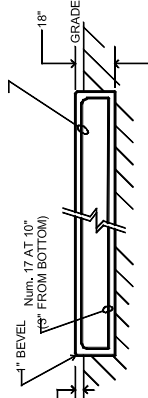

REV.	DATE	DESCRIPTION	BY
1	11/03/97	Gas Delivery Site EQUIPMENT LAYOUT AND FOUNDATION DETAILS	Acme Gas Storage
2	11/07/97	Acme Watertown, Billingsworth 119-2a	DISTRICT 9
3	11/01/97		FILE SHEET
4			REV. 9

  

SCALE	SHEET	OF	DWG NO.
	NONE	1	1

  

COMPANY URL	REVISION DESCRIPTION	DATE	BY
<a href="http://www.autosketch.com">http://www.autosketch.com</a>			CHUCK APPD



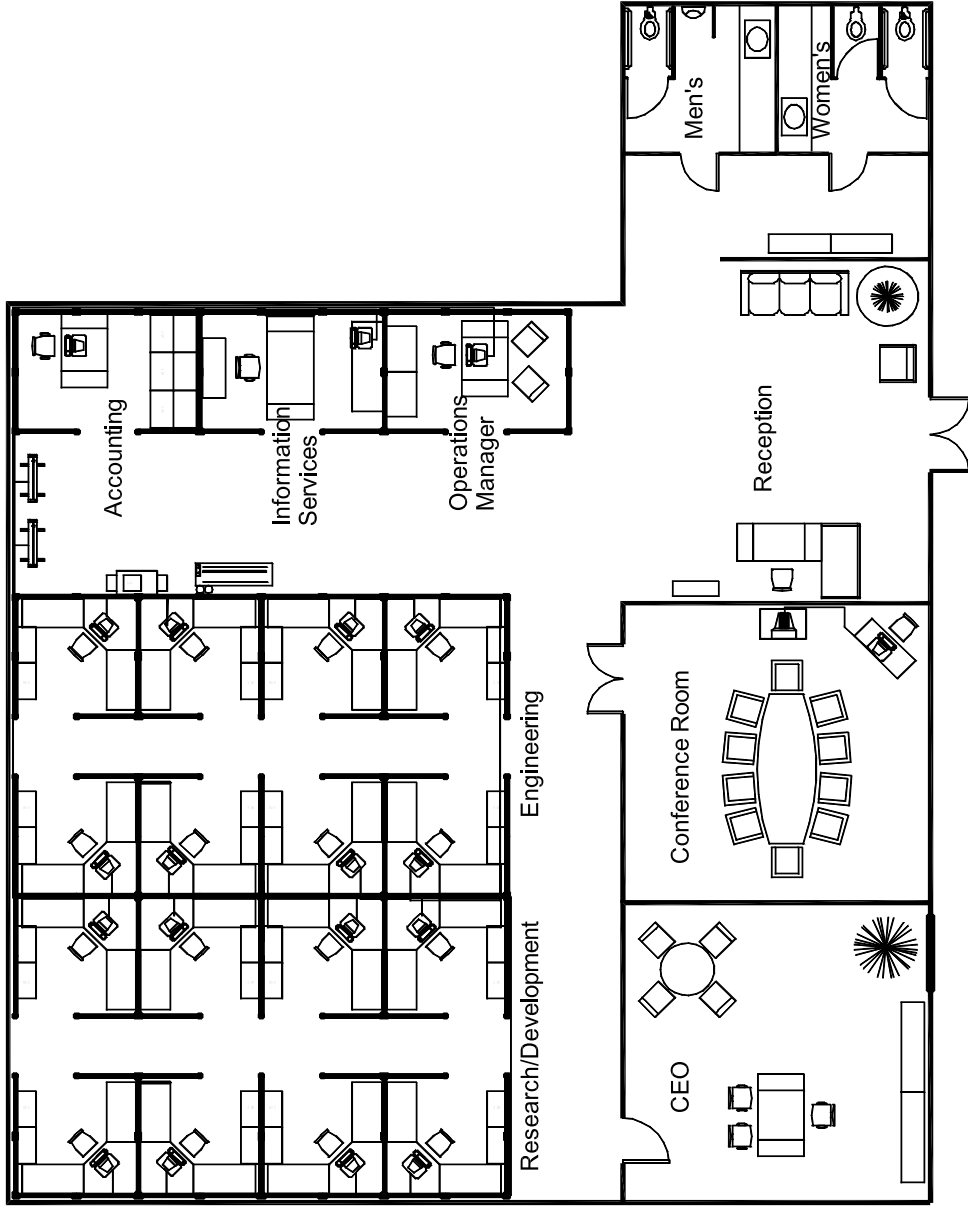

Utopia – Created using the Building wizard

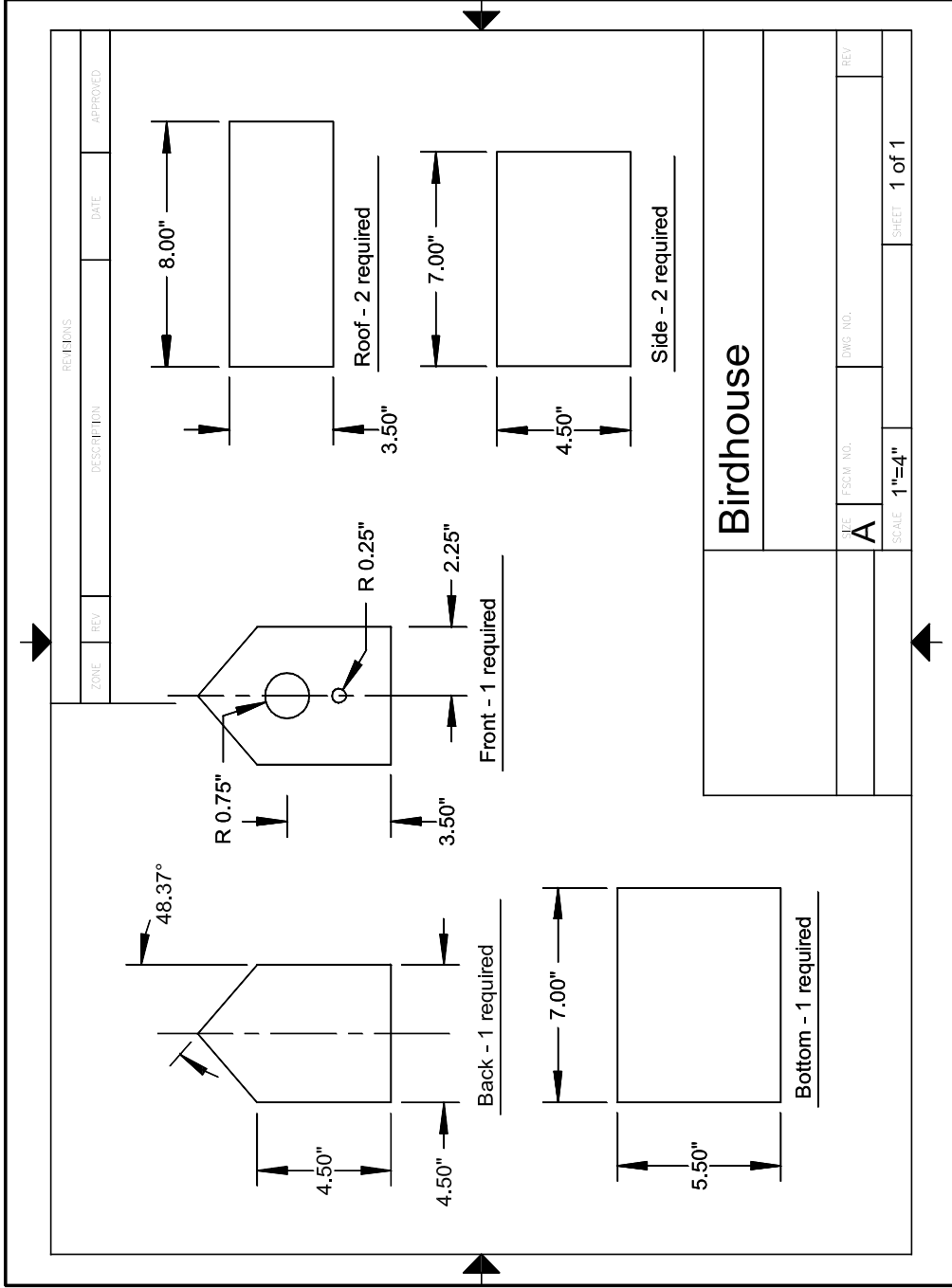

Birdhouse – created using the Workbench wizard



# Index

## A

- absolute coordinates
  - Absolute Coordinates dial, 29
  - defined, 34
- Absolute Coordinates dial
  - defined, 29
- activating
  - buttons in toolsets, 25
  - drawing windows, 23
  - snaps, 38
- active button, in toolset, 25
- Add or Remove Programs window, 4
- alignment
  - with grids, 36
  - lock modifier and, 38
- All-In-One toolbar, 25
  - illustration, 25
- Arc toolset, 26
- arcs, 32
- AutoPoint Indicator, 38
- Autorun feature, 3
- AutoSketch
  - features and functionality, 31
  - installation, 3
  - overview, 18
  - registering, 3
  - repairing installation, 4
  - starting, 18
  - system requirements, 2
  - uninstalling, 4
- AutoSketch Product Registration wizard, 3

## B

- base entities, 32

- birdhouse drawing
  - sample drawing, 45
- blank drawings, creating, 20
- browsers, 2
- Building wizard, 20, 44
- buildings
  - creating drawings for, 20
- buttons
  - on toolbars, 25
  - in toolsets, 25
  - tooltips, 30
  - triangle symbol on, 30

## C

- Cartesian coordinates, 34
- CD-ROMs
  - AutoSketch installation, 3
  - hardware requirements, 2
- Centerpoint snap symbol, 38
- centerpoints
  - snapping, 38
- Circle toolset, 26
- circles
  - defined, 32
- Circular button (Grid toolbar), 36
- circular reference grid, 36
- color
  - fill color, 28, 32
  - setting with property bar, 29
- compound entities, 32
- Content Librarian
  - defined, 28
  - efficiency and, 10
  - illustration, 28

- inserting symbols, 14
- coordinates
  - absolute coordinates, 34
  - Absolute Coordinates dial, 29
  - defined, 11, 34
  - drawing origin and, 35
  - grid origin and, 37
  - illustration, 35
  - isometric coordinates, 34
  - polar coordinates, 34
  - relative coordinates, 29, 34
  - Relative Coordinates dial, 29
  - xy (Cartesian) coordinates, 34
- Create Precision Drawing wizard, 20
- Curve toolset, 26
- curves, 32

## D

- deleting
  - entities from drawings, 13
- detail views, 12, 32
- Diagram wizard, 21, 42
- dials on status bar, 29
- Dimension toolset, 26
- dimensions
  - accuracy, 11
  - adding to drawings, 15
  - defined, 32
  - text in, 15
  - tools for, 26
- displaying
  - detailed Help for tools on toolbars, 30
- docking toolbars, 30
- Double Grid Size button (Grid toolbar), 37
- drawing area. *See* drawing window
- drawing objects. *See* entities
- drawing origin, 35
  - illustration, 35
- drawing scale
  - defined, 34
  - overview, 8
- drawing tools, efficiency and, 10
- drawing window, 23
- drawings
  - accuracy and, 11, 20, 37
  - dimensions, 15, 34
  - drafting vs. AutoSketch, 8
  - drawing scale, 8, 34
  - editing, 13
  - examples of, 45
  - multiple windows, 12
  - opening, 18, 22
  - organizing information in layers, 9, 29
  - repetitive tasks in, 10
  - starting, 18
  - starting from templates, 18, 21

- starting with wizards, 18, 19
- viewing, 12

Duplicate toolset, 26

## E

- edit bar, 28
  - illustration, 28
- editing
  - dimensions and dimension text, 15
  - drawings, 13
  - edit bar, 28
  - efficiency and, 10
  - templates, 21
- electronic schematic wizards, 21
- ellipses, 32
- Endpoint snap symbol, 38
- entities
  - base, 32
  - compound, 32
  - defined, 9
  - deleting, 13
  - edit bar, 28
  - overview, 32
  - properties, 33
  - snapping into place, 11
  - types of, 32
- erasing, ease of, 13
- examples of drawings, 45

## F

- fields
  - defined, 33
- files
  - opening, 18, 22
  - templates, 22
- fill color
  - in Content Librarian, 28
  - fills, defined, 32
  - setting with property bar, 29
- Fill toolset, 27
- fills, 32
- floor designs
  - in office design, 20
- flowchart wizards, 21
- flyouts (on toolbars). *See* toolsets

## G

- geometric properties, 33
- graphic properties, 33
- grid origin, 37
- Grid toolbar, 36
- grid. *See* reference grid
- Gridpoint snap symbol, 38

- gridpoint snaps
  - precision and, 36
  - symbol, 38
- groups
  - defined, 32

## H

- Halve Grid Size button (Grid toolbar), 37
- hard disks
  - hardware requirements, 3
- hardware requirements, 2
- hatches
  - in Content Librarian, 28
  - fills, defined, 32
- Help, displaying, 30
- horizontal alignment of entities, 38

## I

- Inquire toolset, 27
- inserting
  - dimensions, 15
  - symbols, 14, 28
- installing
  - AutoSketch program, 3
- Internet Explorer, 2
- Intersection snap symbol, 38
- intersections
  - snapping to, 38
- isometric coordinates, 34
- Isometric Left button (Grid toolbar), 37
- isometric reference grid, 36
- Isometric Right button (Grid toolbar), 37
- Isometric Top button (Grid toolbar), 36

## J

- jig drawing, 41

## L

- layers
  - organizing information in, 9
  - setting with property bar, 29
- Line toolset, 26
- lines
  - defined, 32
- lock modifier, 38
  - defined, 31
  - illustration, 38
- Lock toolset, 27
- logic diagram wizards, 21

## M

- manual drafting
  - accuracy and, 11
  - compared to AutoSketch, 8
  - layers, 9
  - repetitive tasks in, 10
  - viewing entire drawings, 12
- Marker toolset, 26
- markers, 32
- measurement systems
  - drawing scale and, 8
- Mechanical Part wizard, 21, 41
- mechanical projects, 20
- memory requirements, 2
- menu bar, 28
  - illustration, 29
- Microsoft Internet Explorer, 2
- Midpoint snap symbol, 38
- moving
  - drawing origin, 35
  - toolbars, 30

## N

- networking diagram wizards, 21

## O

- objects. *See* entities
- office layout
  - creating drawings for, 20
  - sample drawing, 40
- Office Layout wizard
  - overview, 20
  - sample drawing, 40
- OLE objects, 33
- Open tab (Start Up dialog box), 22
- opening
  - AutoSketch, 18
  - drawings, 18, 22
  - drawings with wizards, 18
  - templates, 18, 22
  - toolsets, 30
  - wizards, 19
- operating system requirements, 2
- organization chart wizards, 21
- orthogonal alignment, 38
- output, drawing scale and, 34

## P

- panning drawings
  - defined, 12
- patterns, 29
- PC board layout wizards, 21
- Picture/Detail View toolset, 27

- pictures, 33
- pipng wizards, 21
- polar coordinates, 34
- Polygon toolset, 26
- polygons
  - defined, 33
- Polyline toolset, 26
- polylines
  - defined, 33
- precision drawings
  - AutoSketch and accuracy, 11
  - creating drawings, 20
  - snap feature and, 37
- previewing templates, 21
- printing
  - drawing scale and, 34
- properties
  - defined, 33
  - types of, 33
- property bar, 29
  - illustration, 29

## R

- Rectangular button (Grid toolbar), 36
- rectangular reference grid, 36
- redefined symbols, updating, 14
- reference grids
  - defined, 36
  - grid origin, 37
  - illustration, 36
  - settings and alignment, 36
  - types of, 36
- registering AutoSketch, 3
- relative coordinates, 29, 34
- Relative Coordinates dial, 29
- removing
  - entities from drawings, 13
- repairing AutoSketch installation, 4
- repetitive tasks, 10
- replacing redefined symbols, 14

## S

- sample drawings, 45
- schedule wizards, 21
- schematic wizards, 21
- Select toolset, 25
- site map wizards, 21
- size
  - drawing scale and, 34
- snap feature
  - defined, 11, 37
  - grid alignment features, 36
  - lock modifier and, 38
  - snap points, 37
- snap points, 37

- Snap toolset, 27
- Start Up dialog box
  - Open tab, 22
  - options for starting drawings, 18
  - Template tab, 21
  - Wizard tab, 19
- starting
  - AutoSketch, 18
  - drawings, 18
  - drawings from templates, 18, 21
  - drawings with wizards, 18, 19
- status bar
  - defined, 29
  - dials, 29
  - illustration, 29
- styles, 29
- symbol libraries, 28
- Symbol toolset, 27
- symbols
  - defined, 33
  - inserting, 14, 28
  - redefined, 14
- system requirements for AutoSketch, 2

## T

- Template tab (Start Up dialog box), 21
- templates
  - defined, 21
  - opening, 22
  - starting drawings from, 18, 21
- test site drawing, 42
- text
  - defined, 33
  - dimension text, 15
- Text toolset, 26
- title bar, 30
  - illustration, 30
- toolbars
  - All-In-One toolbar, 25
  - defined, 30
  - illustration showing toolset, 30
  - moving and docking, 30
  - toolsets, 30
- tools, efficiency and, 10
- toolsets
  - accessing on toolbars, 30
  - defined, 25
  - triangle symbol, 30
- tooltips, 30
  - illustration, 30
- Transform toolset, 27
- triangle symbol on buttons, 30
- Trim toolset, 27
- troubleshooting, AutoSketch installation
  - (repair), 4
- tuner diagram drawing, 43

## U

uninstalling AutoSketch, 4  
updates

    changed symbols, 14

user interface

    All-In-One toolbar, 25

    Content Librarian, 28

    drawing windows, 23

    edit bar, 28

    elements (illustrated), 23

    menu bar, 28

    property bar, 29

    status bar, 29

    title bar, 30

    tooltips, 30

utopia drawing, 44

## V

vertical alignment of entities, 38

viewing drawings

    detail views, 12

    multiple windows, 12

    zooming and panning, 12

views

    detail views, 12

    multiple windows, 12

## W

Web browsers, 2

Web sites

    mapping wizards, 21

windows in AutoSketch

    defined, 12

    drawing windows, 23

Wizard tab (Start Up dialog box), 19

wizards

    AutoSketch Product Registration wizard, 3

    Building wizard, 20, 44

    Create Precision Drawing wizard, 20

    defined, 19

    Diagram wizard, 21, 42, 43

    Mechanical Part wizard, 21, 41

    Start Up wizards, 19

    Workbench wizard, 20, 45

woodworking projects, 20

Workbench wizard, 20, 45

## X

xy (Cartesian) coordinates, 34

## Z

Zoom toolset, 25

zooming in or out

    defined, 12

